

SpellIndia

INDIA'S **1**
No.

SPELLING BEE

Preparatory Study Material
Provider

www.phonicstore.com

ICSE ACADEMY
www.spellbeeacademy.com



Past Year Papers

Chapter-wise

PREPARE

for

ICSE

Class 10

Chemistry

2013 - 2023



ICSE ACADEMY: How to Prepare for ICSE Class 10 exams

<https://www.spellbeeacademy.com/icse.html>



How to Prepare for ICSE Class 10 exams : Free Resources

Please click on subject to proceed further.

We will keep adding resources here till "March 2026".

So, save this link, keep visiting and stay updated.

(Resources include : Syllabus, Past Year Papers, Specimen Papers, Competency based Questions, Books pdf downloadable, 350+ Term Papers / Prelim Papers of various schools - across subjects, etc.)

- | | | | |
|--------------------------|-----------------------|--------------------------|-----------------------|
| 01 English Literature | 02 English Language | 03 Geography | 04 History & Civics |
| 05 Physics | 06 Chemistry | 07 Mathematics | 08 Biology |
| 09 Computer Applications | 10 Physical Education | 11 Hindi | 12 Commercial Studies |
| 13 Economics | 14 Technical Drawing | 15 Environmental Science | 16 Home Science |
| 17 Gujarati | 18 Marathi | 19 French | |



SCAN QR code to buy the book at amazon NOW.

SpellIndia
INDIA's No. 1 SPELLING BEE
Preparatory Study Material Provider
www.spellindia.com

ICSE ACADEMY
www.spellbeeacademy.com

Pati's

PREPARE
for
ICSE
Classes 9 & 10
ENGLISH GRAMMAR
(includes Board Specimen Papers of 5 years & Competency-focused questions)

28 YEARS Past Questions

75 Practice TESTS

Authoring to **2024-2027** exams

Debashis Pati
Author is the 1st individual to write preparatory books on various topics of "multiple" Spelling Bee competitions in India. He has written the Maximum Number of Spelling Books as well as Tests in the world.

10 / Vocabulary / Grammar Olympiad Exam conductor.



SpellIndia
INDIA's No. 1 SPELLING BEE
Preparatory Study Material Provider
www.spellindia.com

ICSE ACADEMY
www.spellbeeacademy.com

Pati's

PREPARE
for
ICSE
Class 10
(Acts 3 to 5 only)
Julius Caesar

1000+ Practice QUESTIONS*

30 Practice TESTS
(From past questions of 30 schools)

Past Years' Questions (13 years: 1990 onwards)
Competency focused Questions (1 year)
Multiple choice Questions (850+ nos*)
Extract based Questions (85+ extracts*)
*Excludes the questions in the 12 past years' questions and the 30 tests.

Authoring to **2024-2027** exams

Debashis Pati
Author is the 1st individual to write preparatory books on various topics of "multiple" Spelling Bee competitions in India. He has written the Maximum Number of Spelling Books as well as Tests in the world.

10 / Vocabulary / Grammar Olympiad Exam conductor.



SpellIndia
INDIA's No. 1 SPELLING BEE
Preparatory Study Material Provider
www.spellindia.com

ICSE ACADEMY
www.spellbeeacademy.com

Pati's

PREPARE
for
ICSE
Class 10
HINDI GRAMMAR
350+ Sample practice questions & # 51 Tests

350+ SAMPLE QUESTIONS

51 TEST PAPERS

Authoring to **2025 / 2026** onwards

तामसी पति
Tamasee Pati



SpellIndia
INDIA's No. 1 SPELLING BEE
Preparatory Study Material Provider
www.spellindia.com

ICSE ACADEMY
www.spellbeeacademy.com

Pati's

PREPARE
for
ICSE
Class 10
CIVICS

40 TEST PAPERS

The TESTS are based on the Prelim / Pre-board papers of various schools. Answers are provided for all.
Competency Based Questions and 3 Specimen Papers are provided.

Authoring to **2024 / 2025** EXAM

Debashis Pati
Author of ICSE Test Paper series.
He has written the Maximum Number of Spelling Books as well as Tests in the world.



Scan QR code for Free Access to 500+ Prelim Papers across 20 subjects

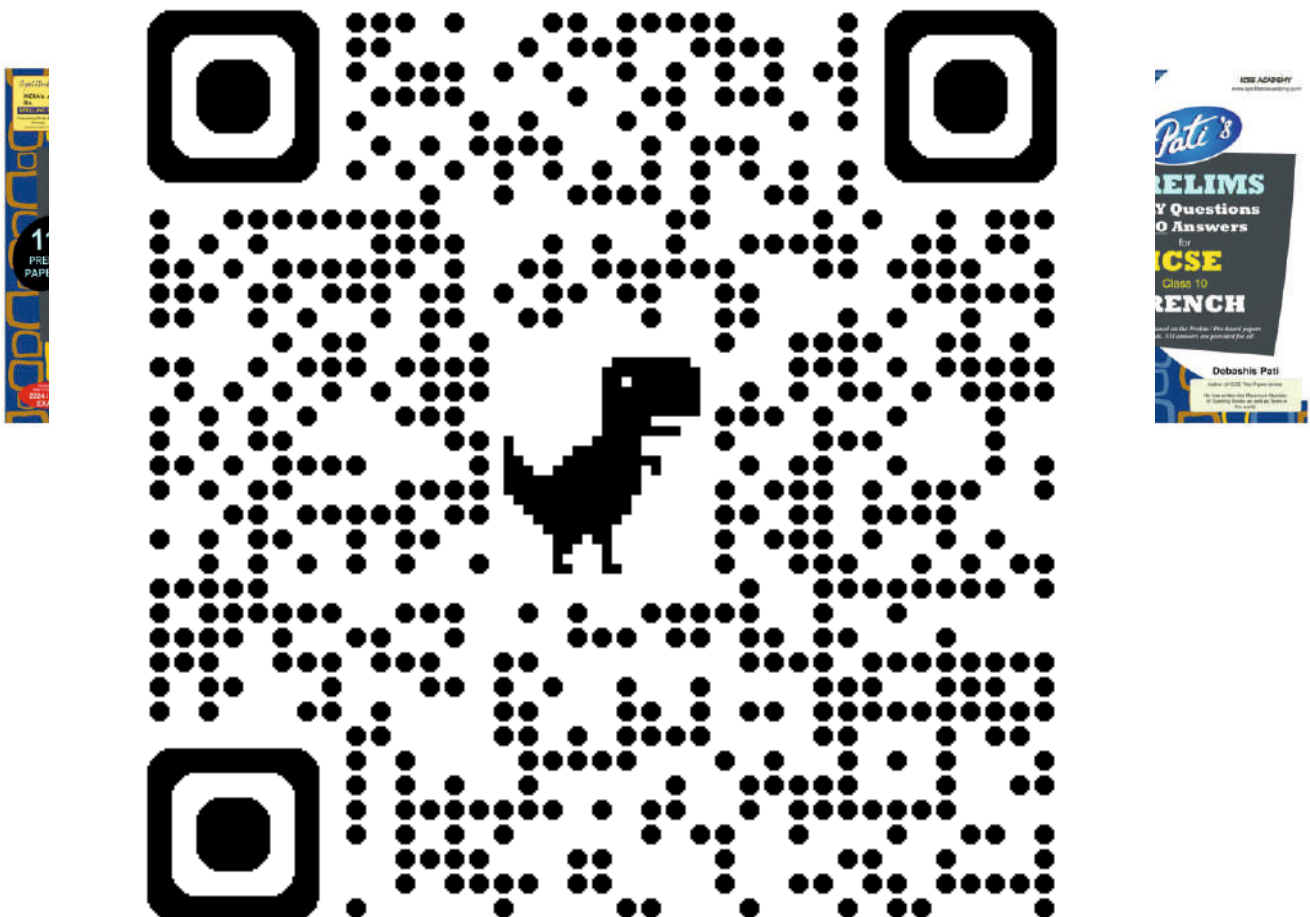
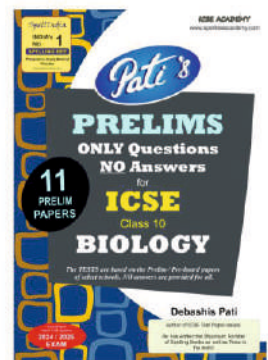
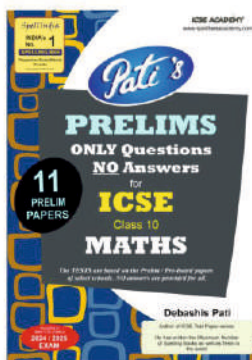
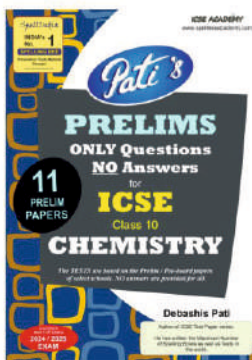
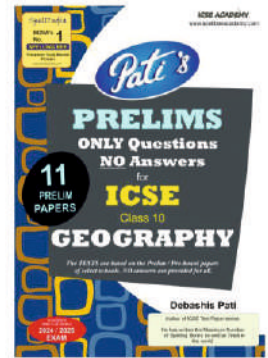
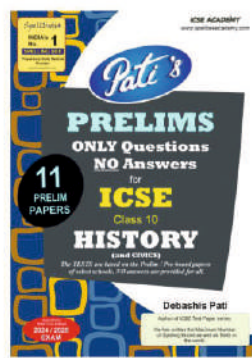
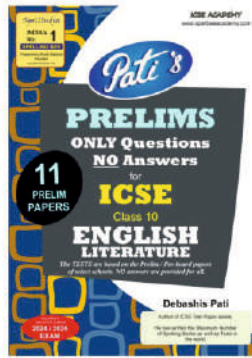
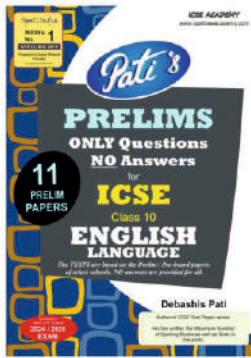



ICSE ACADEMY

Prepare for ICSE CLASS 10 Chemistry Free Resources

SCAN QR CODE Now





ICSE ACADEMY

Past Year Papers

Chapter-wise

2013 - 2023

Note : There was no board exam in 2021 and 2022 due to COVID.

Periodic Properties

2023

Q. 1. Choose the correct answer to the question from the given options. (Do not copy the questions, write the correct answer only).

(i) An element in period 3, whose electron affinity is zero : [1]

- (a) Neon (b) Sulphur
(c) Sodium (d) Argon

(ii) An element with the largest atomic radius among the following is : [1]

- (a) Carbon (b) Nitrogen
(c) Lithium (d) Beryllium

Q. 2. (iv) State the term/process for the following : [1]

- (a) The energy released when an atom in the gaseous state accepts an electron to form an anion.

Q. 3. (iii) Arrange the following as per the instruction given in the brackets : [3]

- (a) Al, K, Mg, Ca (decreasing order of its reactivity)
(b) N, Be, O, C (increasing order of non-metallic character)
(c) P, Si, F, Be (decreasing order of valence electrons)

Q. 6. (i) Define/State : [1]

- (a) Electronegativity

Q. 7. (ii) Give reason for the following : [2]

- (a) Ionisation potential decreases down a group.
(b) Ionic compounds do not conduct electricity in solid state.

2020

Q. 1. (a) Choose the correct answer from the options given below : [1]

(i) The element with highest ionization potential, is :

- (A) Hydrogen (B) Caesium
(C) Radon (D) Helium

(g) Give one word or a phrase for the following statements : [1]

(iv) The tendency of an atom to attract electrons to itself when combined in a compound.

Q. 2. (a) The following table represent the elements and the atomic number. [3]

With reference to this, answer the following using only the alphabets given in the table.

Element	Atomic number
<i>P</i>	13
<i>Q</i>	7
<i>R</i>	10

(i) Which element combines with hydrogen to form a basic gas ?

- (h) Match the atomic number 2, 4, 8, 15 and 19 with each of the following : [5]
- A solid non metal belonging to the third period.
 - A metal of valency 1.
 - A gaseous element with valency 2.
 - An element belonging to Group 2.
 - A rare gas.

- Q. 2. (a)** Arrange the following as per the instruction given in the brackets : [4]
- He, Ar, Ne (Increasing order of the number of electron shells)
 - Na, Li, K (Increasing Ionisation Energy)
 - F, Cl, Br, (Increasing electronegativity)
 - Na, K, Li (Increasing atomic size)

2016

- Q. 1. (b)** Choose the correct answer from the options given below : [1]
- An element with the atomic number 19 will most likely combine chemically with the element whose atomic number is :
(A) 17 (B) 11 (C) 18 (D) 20
- (e) Identify the term/substance in each of the following : [2]
- The tendency of an atom to attract electrons to itself when combined in a compound.
 - The electrons present in the outermost shell of an atom.
- (h) (ii) Rewrite the following sentences by using the correct symbol > (greater than) or < (less than) in the blanks given : [2]
- The ionization potential of Potassium is that of Sodium.
 - The electronegativity of Iodine is that of Chlorine.

- Q. 2. (a)** Use the letters only written in the Periodic Table given below to answer the questions that follow : [4]

	I	II	GROUPS						III	IV	V	VI	VII	0
1														L
2	Q							E	G	J	Z	M		
3	R													
4	T													
5														

- State the number of valence electrons in atom J.
 - Which element shown forms ions with a single negative charge ?
 - Which metallic element is more reactive than R ?
 - Which element has its electrons arranged in four shells ?
- (b) Fill in the blanks by selecting the correct word from the brackets : [2]
- If an element has a low ionization energy then it is likely to be (metallic/non metallic).
 - If an element has seven electrons in its outermost shell then it is likely to have the (largest/smallest) atomic size among all the elements in the same period.

2015

- Q. 1. (b)** Choose the most appropriate answer of the following :
- (i) Among the elements given below, the element with the least electronegativity is :
 (A) Lithium (B) Carbon
 (C) Boron (D) Fluorine [1]
- (h) (ii) The metals of Group 2 from top to bottom are Be, Mg, Ca, Sr, and Ba.
 (1) Which one of these elements will form ions most readily and why ?
 (2) State the common feature in the electronic configuration of all these elements. [3]

- Q. 2. (a)** Arrange the following as per the instructions given in the brackets :
- (i) Ca, Na, Li, K, Rb (increasing order of metallic character)
 (ii) Mg, Cl, Na, S, Si (decreasing order of atomic size)
 (iii) Na, K, Cl, Si (increasing order of ionization energy)
 (iv) Cl, F, Br, I (increasing order of electron affinity) [4]
- (b) Choose the most appropriate answer from the following list of oxides which fit the description. Each answer may be used only once :
 [SO₂, SiO₂, Al₂O₃, MgO, CO, Na₂O]
- (i) A basic oxide.
 (ii) An oxide which dissolves in water forming an acid.
 (iii) An amphoteric oxide.
 (iv) A covalent oxide of a metalloid. [4]

2014

- Q. 1. (a)** Choose the correct answer from the options given below :
- (i) Ionisation Potential increases over a period from left to right because the :
 (A) Atomic radius increases and nuclear charge increases
 (B) Atomic radius decreases and nuclear charge decreases
 (C) Atomic radius increases and nuclear charge decreases
 (D) Atomic radius decreases and nuclear charge increases. [1]
- (vi) If an element A belongs to Period 3 and Group II then it will have :
 (A) 3 shells and 2 valence electrons
 (B) 2 shells and 3 valence electrons
 (C) 3 shells and 3 valence electrons
 (D) 2 shells and 2 valence electrons [1]
- (c) Give one word or phrase for the following :
- (v) The amount of energy released when an atom in the gaseous state accepts an electron to form an anion. [1]

2013

- Q. 1. (f)** Choose the most appropriate answer from the following options :
- (i) Among the period 2 elements, the element which has high electron affinity is :
 (A) Lithium (B) Carbon
 (C) Chlorine (D) Fluorine [1]

Q. 2. (a)

Group Number	IA	IIA	IIIA	IVA	VA	VIA	VIIA	0
	1	2	13	14	15	16	17	18
2nd period	Li		D			O	J	Ne
	A	Mg	E	Si		H	M	
	R	T	I		Q	u		y

- In this table H does not represent hydrogen.
- Some elements are given in their own symbol and position in the periodic table.
- While others are shown with a letter.

With reference to the table answer the following questions :

- (i) Identify the most electronegative element. [1]
 - (ii) Identify the most reactive elements of group 1. [1]
 - (iii) Identify the element from period 3 with least atomic size. [1]
 - (iv) How many valence electrons are present in Q ? [1]
 - (v) Which element from group 2 would have the least ionization energy ? [1]
 - (vi) Identify the noble gas of the fourth period. [1]
 - (vii) In the compound between A and H what type of bond would be formed and give the molecular formula for the same. [1]
- Q. 7. (b)** Identify the following substance which is underlined :
- (v) The element which has the highest ionization potential. [1]



Chemical Bonding

2023

Q. 5. (ii) Draw the electron dot structure for the following : [2]

- (a) Ammonium ion
 - (b) A molecule of nitrogen
- [At. No. : N = 7, H = 1]

Q. 8. (iv) Choose the answer from the list which fits in the description : [2]

[CCl₄, PbO, NaCl, CuO, NH₄Cl]

- (a) A compound which undergoes thermal dissociation.
- (c) A compound which is non-electrolyte.

2020

Q. 1. (a) Choose the correct answer from the options given below : [1]

(iii) A compound with low boiling point, is :

- (A) Sodium chloride
- (B) Calcium chloride
- (C) Potassium chloride
- (D) Carbon tetrachloride

(g) Give one word or a phrase for the following statement : [1]

(i) The chemical formed by a shared pair of electrons, each bonding atom contributing one electron to the pair.

(h) Fill in the blank from the choices given in bracket : [1]

(i) The polar covalent compound in gaseous state that does not conduct electricity is (carbon tetra chloride, ammonia, methane)

Q. 2. (b) Draw the electron dot diagram for the compounds given below. Represent the electrons by (.) and (x) in the diagram. [3]

[Atomic No. : Ca = 20, O = 8, Cl = 17, H = 1]

- (i) Calcium oxide
- (ii) Chlorine molecule
- (iii) Water molecule

2019

- Q. 2. (a)** Draw the electron dot structure of : [3]
- (i) Nitrogen molecule [N = 7]
 - (ii) Sodium chloride [Na = 11, Cl = 17]
 - (iii) Ammonium ion [N = 7, H = 1]

2018

- Q. 1. (b)** Give one word or a phrase for the following statement : [1]
- (iii) The tendency of an element to form chains of identical atoms.
- (h)** Fill up the blank with the correct choice given in bracket : [1]
- (i) Ionic or electrovalent compounds do not conduct electricity in their state. (fused/solid)
- Q. 2. (a)**
- (i) What do you understand by a lone pair of electrons?
 - (ii) Draw the electron dot diagram of Hydronium ion. (H = 1; O = 8) [3]

2017

- Q. 1. (a)** Fill in the blank from the choices given in bracket : [1]
- (ii) The compound that does not have a lone pair of electron is (water, ammonia, carbon tetra chloride)
- (b)** Choose the correct answers from the options given below : [1]
- (iii) Which of the following is a common characteristic of a covalent compound ?
 1. High melting point
 2. Consists of molecules
 3. Always soluble in water
 4. Conducts electricity when it is in the molten state
- Q. 2. (b)** State the type of Bonding in the following molecules : [2]
- (i) Water
 - (ii) Calcium oxide
- Q. 3. (a)** Draw an electron dot diagram to show the formation of each of the following compounds : [4]
- (i) Methane
 - (ii) Magnesium Chloride [H = 1, C = 6, Mg = 12, Cl = 17]

2016

- Q. 1. (b)** Choose the correct answer from the options given below : [1]
- (ii) The ratio between the number of molecules in 2g of hydrogen and 32g of oxygen is :

(A) 1 : 2	(B) 1 : 0.01
(C) 1 : 1	(D) 0.01 : 1 [Given that H = 1, O = 16]

- Q. 2. (c)** The following table shows the electronic configuration of the elements W, X, Y, Z :

Element	W	X	Y	Z
Electronic configuration	2, 8, 1	2, 8, 7	2, 5	1

Answer the following questions based on the table above :

- (i) What type of Bond is formed between : [2]
 1. W and X
 2. Y and Z
- (ii) What is the formula of the compound formed between : [2]
 1. X and Z
 2. W and X

- Q. 5. (d)** By drawing an electron dot diagram show the formation of Ammonium Ion [Atomic No. : N = 7 and H = 1] [2]

2015

- Q. 1. (b)** Choose the most appropriate answer for the following :
- (iv) Bonding in this molecule can be understood to involve coordinate bonding.
 (A) Carbon tetrachloride (B) Hydrogen
 (C) Hydrogen chloride (D) Ammonium chloride [1]
- (f) Give appropriate scientific reason for the following statement :
 (ii) Carbon tetrachloride does not conduct electricity. [1]
- (h) Answer the following question :
 (i) Explain the bonding in methane molecule using electron dot structure. [2]
- Q. 2. (c)** Element X is a metal with a valency 2, Y is a non-metal with a valency 3.
 (i) Write an equation to show how Y forms an ion.
 (ii) If Y is a diatomic gas, write an equation for the direct combination of X and Y to form a compound. [2]
- Q. 7. (b)** An element L consists of molecules.
 (i) What type of bonding is present in the particles that make up L ?
 (ii) When L is heated with iron metal, it forms a compound FeL. What chemical term would you use to describe the change undergone by L ? [2]

2014

- Q. 1. (a)** Choose the correct answers from the options given below :
- (ii) A compound X consists of only molecules. Hence X will have :
 (A) A crystalline hard structure
 (B) A low melting point and low boiling point
 (C) An ionic bond
 (D) A strong force of attraction between its molecules. [1]
- (vii) The molecule containing a triple co-valent bond is :
 (A) ammonia (B) methane
 (C) water (D) nitrogen [1]
- Q. 6. (b)** (i) Why do covalent compounds exist as gases, liquids or soft solids ? [1½]
 (c) Name the kind of particles solution :
 (i) Sodium Hydroxide solution.
 (ii) Carbonic acid.
 (iii) Sugar solution. [3]
- Q. 7. (a)** An element Z has atomic number 16. Answer the following questions on Z :
 (i) State the period and group to which Z belongs.
 (ii) Is Z a metal or a non-metal ?
 (iii) State the formula between Z and Hydrogen.
 (iv) What kind of a compound is this ? [5]
- (b) M is a metal above hydrogen in the activity series and its oxide has the formula M_2O . This oxide when dissolved in water forms the corresponding hydroxide which is a good conductor of electricity. In the above context answer the following :
 (i) What kind of combination exists between M and O ?
 (ii) How many electrons are there in the outermost shell of M ?
 (iii) Name the group of which M belongs.

- (iv) State the reaction taking place at the cathode. [5]
(v) Name the product at the anode. [1]

2013

- Q. 1.** (d) Give suitable chemical term for the following :
- (i) A bond formed by a shared pair of electrons with both electrons coming from the same atom. [1]
- (f) Choose the most appropriate answer from the following options :
- (ii) Among the following compounds identify the compound that has all three bonds (ionic, covalent and coordinate bond) :
- (A) Ammonia (B) Ammonium chloride [1]
(C) Sodium hydroxide (D) Calcium chloride [1]
- (ix) Which of the following is not a typical property of an ionic compound ?
- (A) High melting point
(B) Conducts electricity in the molten and in the aqueous solution state.
(C) They are insoluble in water.
(D) They exist as oppositely charged ions even in the solid state. [1]
- Q. 2.** (b) Compare the compounds carbon tetrachloride and sodium chloride with regard to solubility in water and electrical conductivity. [2]

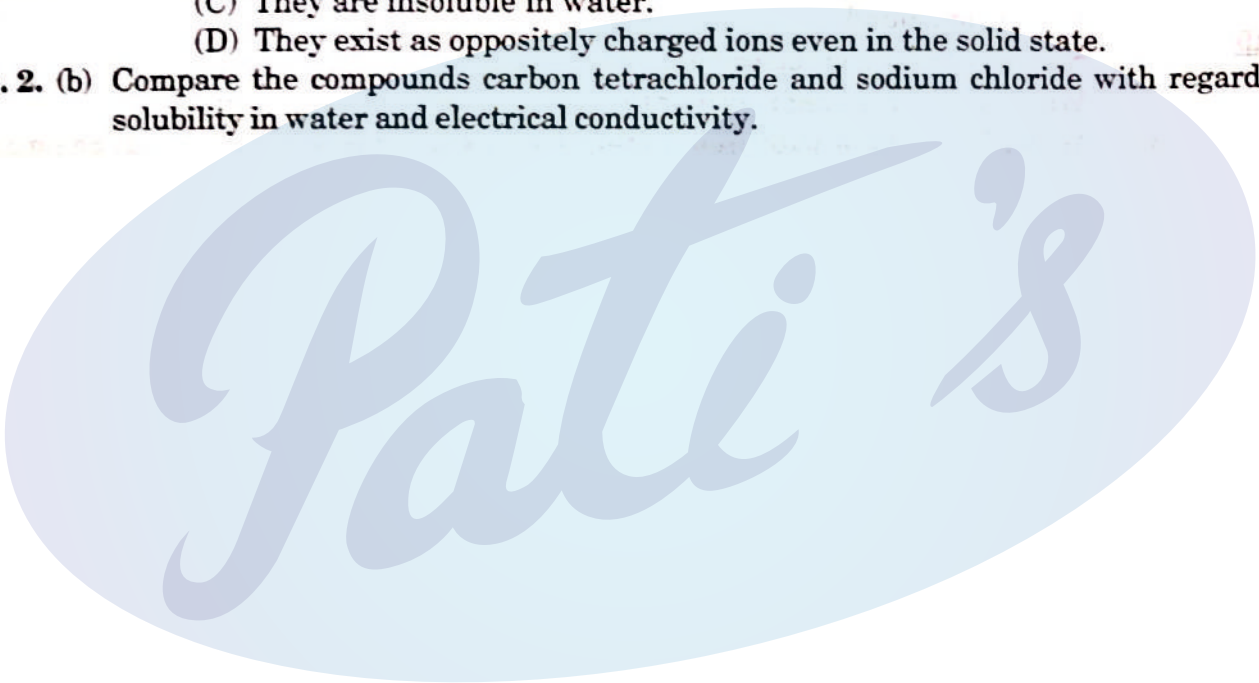

Study of Acid, Base and Salts

2023

Q. 1. Choose the correct answer to the question from the given options. (Do not copy the questions, write the correct answer only).

(xiii) The acid which does not form acid salt by a basic radical : [1]

- (a) H_2CO_3 (b) H_3PO_4
(c) H_2SO_4 (d) CH_3COOH

(xv) The indicator which changes to pink colour in an alkaline solution is : [1]

- (a) Blue Litmus (b) Methyl Orange
(c) Red Litmus (d) Phenolphthalein

Q. 2. (iii) Fill in the blank with the choices given in the bracket : [1]

(c) Higher the pH value of a solution, the more..... [acidic/alkaline] it is.

(iv) State the terms/process for the following : [1]

(d) A type of salt formed by partial replacement of hydroxyl radicals with an acid radical.

Q. 8. (ii) Differentiate between the following pairs based on the criteria given in the brackets : [2]

- (a) Cane sugar and hydrated copper sulphate [using concentrated H_2SO_4]
(b) Sulphuric acid and hydrochloric acid [type of salts formed]

2020

Q. 1. (e) State one relevant reason for each of the following : [1]

(iii) Hydrated copper sulphate crystals turn white on heating.

(h) Fill in the blanks from the choices given in brackets : [2]

(ii) A salt prepared by displacement reaction is
(ferric chloride, ferrous chloride, silver chloride)

(iv) An alkali which completely dissociates into ions is
(ammonium hydroxide, calcium hydroxide, lithium hydroxide)

- Complete the following by selecting the correct option from the choices given : [1]
- (i) pH of acetic acid is greater than dilute sulphuric acid. So acetic acid contains concentration of H^+ ions. (greater, same, low)
- (iii) The acid which cannot act as an oxidizing agent is
(conc. H_2SO_4 , conc. HNO_3 , conc. HCl)
- Q. 4.** (a) Differentiate between the following pairs based on the information given in the brackets : [1]
(iii) Acid and Alkali (formation of type of ions)
- Q. 6.** (b) Identify the substance underlined in each of the following : [1]
(ii) The acid that is a dehydrating as well as a drying agent.
- Q. 7.** (a) Write balanced chemical equations, for the preparation of the given salts (i) to (iii) by using the methods A to C respectively : [3]
A : Neutralization B : Precipitation C : Titration
(i) Copper sulphate
(ii) Zinc carbonate
(iii) Ammonium sulphate

2019

- Q. 2.** (b) The pH values of three solutions A, B and C are given in the table. Answer the following questions : [3]

Solution	pH value
A	12
B	2
C	7

- (i) Which solution will have no effect on litmus solution ?
(ii) Which solution will liberate CO_2 when reacted with sodium carbonate ?
(iii) Which solution will turn red litmus solution blue ?
- Q. 3.** (c) Choose the method of preparation of the following salts, from the methods given in the list : [4]
[List : A. Neutralization B. Precipitation
C. Direct combination D. Substitution]
- (i) Lead chloride
(ii) Iron (II) sulphate
(iii) Sodium nitrate
(iv) Iron (III) chloride

2018

- Q. 1.** (a) Choose the correct answer from the options given below : [1]
(i) The salt solution which does not react with ammonium hydroxide is :
(A) Calcium Nitrate (B) Zinc Nitrate
(C) Lead Nitrate (D) Copper Nitrate
- (b) Give one word or a phrase for the following statement : [1]
(iv) The property by which certain hydrated salts, when left exposed to atmosphere, lose their water of crystallization and crumble into powder.
- (e) State one relevant observation for each of the following : [3]
(iii) Lead nitrate solution is mixed with dilute hydrochloric acid and heated.
(iv) Anhydrous calcium chloride is exposed to air for some time.
(v) Barium chloride solution is slowly added to sodium sulphate solution.

Q. 7. (b) State what would you observe when :

- (i) Washing Soda Crystals are exposed to the atmosphere.
- (ii) The salt ferric chloride is exposed to the atmosphere. [2]

2015

Q. 1. (g) (i) Give balanced chemical equations for the following conversions A, B and C :

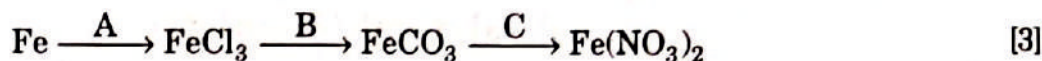

2014

Q. 1. (b) Fill in the blank from the choices given within bracket :

- (i) The basicity of Acetic Acid is (3, 1, 4). [1]

Q. 4. (b) Draw the structure of the stable positive ion formed when an acid dissolves in water. [2]

(c) State the inference drawn from the following observations :

- (iii) pH of liquid R is 10. What kind of substance is R ?
- (iv) Salt S is prepared by reacting dilute sulphuric acid with copper oxide. Identify S. [2]

Q. 5. (c) Give balanced chemical equations to prepare the following salts :

- (i) Lead sulphate from lead carbonate.
- (ii) Sodium sulphate using dilute sulphuric acid.
- (iii) Copper chloride using copper carbonate. [4]

2013

Q. 1. (a) From the list given below, select the word(s) required to correctly complete blanks (i) to (v) in the following passage. The words from the list are to be used only once. Write the answers as (a) (i), (ii), (iii) and so on. Do not copy the passage.

[ammonia, ammonium, carbonate, carbon dioxide, hydrogen, hydronium, hydroxide, precipitate, salt, water] :

- (i) A solution M turns blue litmus red, so it must contain (i) ions; another solution O turns red litmus blue and hence, must contain (ii) ions.
- (ii) When solutions M and O are mixed together, the products will be (iii) and (iv)
- (iii) If a piece of magnesium was put into a solution M, (v) gas would be evolved. [5]

(d) Give suitable chemical terms for the following :

- (ii) A salt formed by incomplete neutralisation of an acid by a base. [1]
- (iv) A definite number of water molecules bound to some salts. [1]
- (v) The process in which a substance absorbs moisture from the atmospheric air to become moist, and ultimately dissolves in the absorbed water. [1]

Q. 3. (a) Choosing the substances from the list given below, write balanced chemical equations for the reactions which would be used in the laboratory to obtain the following salts :

Dilute Sulphuric acid	Copper	Copper (II) carbonate
	Iron	Sodium carbonate
	Sodium	Sodium chloride
		Zinc nitrate

- (i) Sodium sulphate
- (ii) Zinc carbonate
- (iii) Copper (II) sulphate
- (iv) Iron (II) sulphate. [4]

(b) State two relevant observations for each of the following :

- (i) Ammonium hydroxide solution is added to copper (II) nitrate solution in small quantities and then in excess.

- (ii) Ammonium hydroxide solution is added to zinc nitrate solution in minimum quantities and then in excess.
- (iii) Lead nitrate crystals are heated in a hard glass test tube. [6]

Pati's

Analytical Chemistry

2023

Q. 1. Choose the correct answer to the question from the given options. (Do not copy the questions, write the correct answer only).

(ix) The nitrate which on thermal decomposition leaves behind a residue which is yellow when hot and white when cold : [1]

- (a) Lead nitrate (b) Ammonium nitrate
(c) Copper nitrate (d) Zinc nitrate

Q. 2. (iii) Fill in the blank with the choices given in the bracket : [1]

(d), [Silver chloride/Lead chloride] is a white precipitate that is soluble in excess of Ammonium hydroxide solution.

Q. 3. (i) Identify the cation in each of the following cases : [2]

- (a) Ammonium hydroxide solution when added to Solution B gives a white precipitate which does not dissolve in excess of ammonium hydroxide solution.
(b) Sodium hydroxide solution when added to Solution C gives a white precipitate which is insoluble in excess of sodium hydroxide solution.

Q. 5. (iv) Study the following observations and name the anions present in each of the reactions. [3]

- (a) When a crystalline solid 'P' is warmed with concentrated H_2SO_4 and copper turnings a reddish brown gas is released.
(b) When few drops of dilute sulphuric acid is added to Salt 'R' and heated, a colourless gas is released which turns moist lead acetate paper silvery black.
(c) When few drops of barium nitrate solution is added to the salt solution 'Q', a white precipitate is formed which is insoluble in HCl.

Q. 6. (iii) Choose the substances given in the box below to answer the following questions : [1]

Iron	Magnesium	Zinc	Sodium sulphide
Lead	Ferric chloride	Copper	Ferrous sulphate

- (c) The solution of this compound produces dirty green precipitate with NaOH.
(iv) State one relevant observation for each of the following : [1]
(a) To the copper nitrate solution, initially few drop of sodium hydroxide solution is added and then added in excess.

2020

Q. 1. (b) State one relevant observation for each of the following reactions : [1]

(ii) Addition of excess ammonium hydroxide into copper sulphate solution.

(c) Write a balanced chemical equation for each of the following : [1]

(iii) Reaction of lead nitrate solution with ammonium hydroxide.

Q. 5. (a) Distinguish between the following pairs of compounds using a reagent as a chemical test : [2]

- (i) Calcium nitrate and Zinc nitrate solution.
(ii) Ammonium sulphate crystals and Sodium sulphate crystals.

2015

- Q. 4. (b) The following table shows the tests a student performed on four different aqueous solutions which are X, Y, Z and W. Based on the observations provided, identify the cation present : [4]

Chemical Test	Observation	Conclusion
To solution X, ammonium hydroxide is added in minimum quantity first and then in excess.	A dirty white precipitate is formed which dissolves in excess to form a clear solution.	(i)
To solution Y ammonium hydroxide is added in minimum quantity first and then excess.	A pale blue precipitate is formed which dissolves in excess to form a clear inky blue solution.	(ii)
To solution W a small quantity of sodium hydroxide solution is added and then in excess.	A white precipitate is formed which remains insoluble.	(iii)
To a salt Z calcium hydroxide solution is added and then heated.	A pungent smelling gas turning moist red litmus paper blue is obtained.	(iv)

2014

- Q. 1. (f) Distinguish between the following pairs of compound using the test given within brackets : [1]
- (i) Iron (II) sulphate and iron (III) sulphate (using ammonium hydroxide) [1]
- (ii) A lead salt and a zinc salt (using excess ammonium hydroxide). [1]
- Q. 2. (a) State your observation in the following case : [1]
- (ii) When excess sodium hydroxide is added to calcium nitrate solution. [1]
- Q. 4. (c) State the inference drawn from the following observations : [2]
- (i) On carrying out the flame test with a salt P a brick red flame was obtained. What is the cation in P ?
- (ii) A gas Q turns moist lead acetate paper silvery black. Identify the gas Q.

Mole Concept and Stoichiometry

2023

Q. 2. (iv) State the terms/process for the following : [1]

(e) The ratio of the mass of a certain volume of gas to the same volume of hydrogen measured under the same conditions of temperature and pressure.

Q. 4. (iii) Solve the following numerical problem : [3]

Ethane burns in oxygen according to the chemical equation :

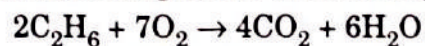

If 80 ml of ethane is burnt in 300 ml of oxygen, find the composition of the resultant gaseous mixture when measured at room temperature.



- Q. 6. (i)** Define/State : [1]
 (b) Gay-Lussac's Law of combining volumes

- (ii) The Empirical formula of an organic compound is CHCl_2 .
 If its relative molecular mass is 168, what is its molecular formula ?
 [At. Wt. C = 12, H = 1, Cl = 35.5] [2]

- Q. 7. (iii)** Calculate : [3]
 (a) The percentage of phosphorus in the fertilizer super phosphate $\text{Ca}(\text{H}_2\text{PO}_4)_2$ correct to 1 decimal point. [At. Wt. H = 1, P = 31, O = 16, Ca = 40]
 (b) Write the empirical formula of C_8H_{18} .

2020

- Q. 1. (f)** Calculate : [5]
 (i) The amount of each reactant required to produce 750 ml of carbon dioxide, when two volumes of carbon monoxide combine with one volume of oxygen to produce two volumes of carbon dioxide.

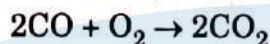

- (ii) The volume occupied by 80 g of carbon dioxide at STP.
 (iii) Calculate the number of molecules in 4.4 gm of CO_2 .
 [Atomic mass of C = 12, O = 16]
 (iv) State the law associated in question no. (f) (i) above.
 (h) Fill in the blanks from the choices given in brackets : [1]
 (iii) The number of moles in 11 gm of nitrogen gas is (0.39, 0.49, 0.29)
 [atomic mass of N = 14]

- Q. 5. (b)** Calculate the percentage of : [3]
 (i) Fluorine
 (ii) Sodium and
 (iii) Aluminum

in sodium aluminium fluoride $[\text{Na}_3\text{AlF}_6]$, to the nearest whole number.
 [Atomic Mass : Na = 23, Al = 27, F = 19]

- (c) (i) State the volume occupied by 40 gm of methane at STP, if its vapour density (V.D.) is 8. [4]
 (ii) Calculate the number of moles present in 160 gm of NaOH.
 [Atomic Mass : Na = 23, H = 1, O = 16]

2019

- Q. 1. (e)** (i) Calculate : [5]
 1. The number of moles in 12 g of oxygen gas. [O = 16]
 2. The weight of 10^{22} atoms of carbon.
 [C = 12, Avogadro's No. = 6×10^{23}]
 (ii) Molecular formula of a compound is $\text{C}_6\text{H}_{18}\text{O}_3$. Find its empirical formula.

- Q. 6. (b)** Copper sulphate solution reacts with sodium hydroxide solution to form a precipitate of copper hydroxide according to the equation : [3]

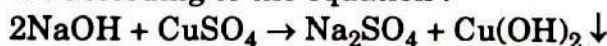

- (i) What mass of copper hydroxide is precipitated by using 200 gm of sodium hydroxide?
 [H = 1, O = 16, Na = 23, S = 32, Cu = 64]
 (ii) What is the colour of the precipitate formed ?

- (c) Find the empirical formula and the molecular formula of an organic compound from the data given below : [4]
 C = 75.92%, H = 6.32% and N = 17.76%
 The vapour density of the compound is 39.5.
 [C = 12, H = 1, N = 14]

2018

- Q. 4.** (a) The percentage composition of a gas is : [2]
 Nitrogen 82.35%, Hydrogen 17.64%
 Find the empirical formula of the gas. [N = 14, H = 1]
- (b) Aluminum carbide reacts with water according to the following equation : [4]

$$\text{Al}_4\text{C}_3 + 12\text{H}_2\text{O} \rightarrow 4\text{Al}(\text{OH})_3 + 3\text{CH}_4$$
- (i) What mass of aluminum hydroxide is formed from 12g of aluminum carbide?
 (ii) What volume of methane at s.t.p. is obtained from 12g of aluminum carbide?
 [Relative molecular weight of $\text{Al}_4\text{C}_3 = 144$; $\text{Al}(\text{OH})_3 = 78$]
- (c) (i) If 150 cc of gas A contains X molecules, how many molecules of gas B will be present in 75 cc of B?
 The gases A and B are under the same conditions of temperature and pressure.
 (ii) Name the law on which the above problem is based. [2]
- Q. 6.** (b) Ethane burns in oxygen to form CO_2 and H_2O according to the equation : [4]

$$2\text{C}_2\text{H}_6 + 7\text{O}_2 \rightarrow 4\text{CO}_2 + 6\text{H}_2\text{O}.$$

If 1250 cc of oxygen is burnt with 300 cc of ethane.

Calculate :

- (i) the volume of CO_2 formed. (ii) the volume of unused O_2 .

2017

- Q. 1.** (g) (i) Calculate the number of gram atoms in 4.6 grams of sodium (Na = 23).
 (ii) Calculate the percentage of water of crystallization in $\text{CuSO}_4 \cdot 5\text{H}_2\text{O}$
 (H = 1, O = 16, S = 32, Cu = 64)
 (iii) A compound of X and Y has the empirical formula XY_2 . Its vapour density is equal to its empirical formula weight. Determine its molecular formula. [5]
- Q. 5.** (a) (i) Propane burns in air according to the following equation :

$$\text{C}_3\text{H}_8 + 5\text{O}_2 \rightarrow 3\text{CO}_2 + 4\text{H}_2\text{O}$$

 What volume of propane is consumed on using 1000 cm^3 of air, considering only 20% of air contains oxygen ?
 (ii) The mass of 11.2 litres of a certain gas at s.t.p. is 24 g. Find the gram molecular mass of the gas. [4]
- (b) A gas cylinder can hold 1 kg of hydrogen at room temperature and pressure : [4]
 (i) Find the number of moles of hydrogen present.
 (ii) What weight of CO_2 can the cylinder hold under similar conditions of temperature and pressure ? (H = 1, C = 12, O = 16)
 (iii) If the number of molecules of hydrogen in the cylinder is X, calculate the number of CO_2 molecules in the cylinder under the same conditions of temperature and pressure.
 (iv) State the law that helped you to arrive at the above result.

2016

- Q. 1.** (f) (i) A gas of mass 32gms has volume of 20 litres at S.T.P. Calculate the gram molecular weight of the gas.

- (ii) How much Calcium oxide is formed when 82g of calcium nitrate is heated? Also find the volume of nitrogendioxide evolved :

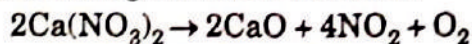

(Ca = 40, N = 14, O = 16)

[5]

- Q. 5.** (a) A gas cylinder contains 12×10^{24} molecules of oxygen gas.

If Avogadro's number is 6×10^{23} ; Calculate :

- (i) the mass of oxygen present in the cylinder.

- (ii) the volume of oxygen at S.T.P. present in the cylinder. [O = 16]

[2]

- (b) A gaseous hydrocarbon contains 82.76% of carbon. Given that its vapour density is 29, find its molecular formula. [C = 12, H = 1]

[3]

- (c) The equation $4\text{NH}_3 + 5\text{O}_2 \rightarrow 4\text{NO} + 6\text{H}_2\text{O}$, represents the catalytic oxidation of ammonia. If 100 cm^3 of ammonia is used calculate the volume of oxygen required to oxidise the ammonia completely.

[3]

2015

- Q. 1.** (b) Choose the most appropriate answer for the following :

- (v) Which of the following would weigh the least ?

(A) 2 gram atoms of Nitrogen.

(B) 1 mole of Silver

(C) 22.4 litres of oxygen gas at 1 atmospheric pressure and 273 K

(D) 6.02×10^{23} atoms of carbon.

[Atomic masses : Ag = 108, N = 14, O = 16, C = 12]

[1]

- (c) Complete the following calculations. Show working for complete credit :

- (i) Calculate the mass of Calcium that will contain the same number of atoms as are present in 3.2 gm of Sulphur.

[2]

[Atomic masses : S = 32, Ca = 40]

- (ii) If 6 litres of hydrogen and 4 litres of chlorine are mixed and exploded and if water is added to the gases formed, find the volume of the residual gas.

[2]

- (iii) If the empirical formula of a compound is CH and it has a vapour density of 13, find the molecular formula of the compound.

[1]

- Q. 5.** (a) Consider the following reaction and based on the reaction answer the questions that follow :

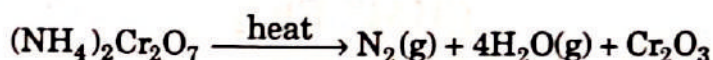

Calculate :

- (i) the quantity in moles of $(\text{NH}_4)_2\text{Cr}_2\text{O}_7$ if 63 gm of $(\text{NH}_4)_2\text{Cr}_2\text{O}_7$ is heated.

[1]

- (ii) the quantity in moles of nitrogen formed.

[1]

- (iii) the volume in litres of dm^3 of N_2 evolved at S.T.P.

[1]

- (iv) the mass in grams of Cr_2O_3 formed at the same time.

[2]

[Atomic masses : H = 1, Cr = 52, N = 14]

2014

- Q. 1.** (c) Give one word or phrase for the following :

- (i) The ratio of the mass of a certain volume of gas to the mass of an equal volume of hydrogen under the same conditions of temperature and pressure.

[1]

- (g) (i) Oxygen oxidises ethyne to carbon dioxide and water as shown by the equation :

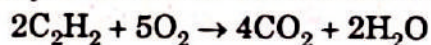

What volume of ethyne gas at s.t.p. is required to produce 8.4 cm³ of carbon dioxide at s.t.p. ? [H = 1, C = 12, O = 16]

- (ii) A compound made up of two elements X and Y has an empirical formula X₂Y. If the atomic weights of X is 10 and that of Y is 5 and the compound has a vapour density 25, find its molecular formula. [5]

Q. 6. (a) (i) State Avogadro's law.

(ii) A cylinder contains 68g of ammonia gas at s.t.p.

- (1) What is the volume occupied by this gas ?
 (2) How many moles of ammonia are present in the cylinder ?
 (3) How many molecules of ammonia are present in the cylinder ?

[N = 14, H = 1]

[4]

2013

Q. 1. (g) Solve the following :

- (i) What volume of oxygen is required to burn completely 90 dm³ of butane under similar conditions of temperature and pressure ?

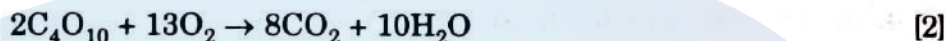

- (ii) The vapour density of a gas is 8. What would be the volume occupied by 24.0 g of the gas at STP ? [2]

- (iii) A vessel contains X number of molecules of hydrogen gas at a certain temperature and pressure. How many molecules of nitrogen gas would be present in the same vessel under the same conditions of temperature and pressure ? [1]

Q. 7. (a) O₂ is evolved by heating KClO₃ using MnO₂ as a catalyst

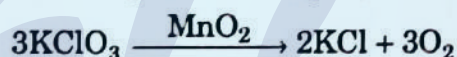

- (i) Calculate the mass of KClO₃ required to produce 6.72 liter of O₂ at STP. [atomic masses of K = 39, Cl = 35.5, O = 16]. [2]

- (ii) Calculate the number of moles of oxygen present in the above volume and also the number of molecules. [2]

- (iii) Calculate the volume occupied by 0.01 mole of CO₂ at STP. [1]

CHAPTER 6

Electrolysis

2023

Q. 1. Choose the correct answer to the question from the given options. (Do not copy the questions, write the correct answer only).

- (v) Which of the following reactions takes place at the anode during the electroplating of an article with silver ? [1]

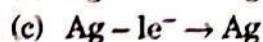
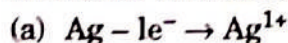

(d) None of the above

Q. 3. (ii) Fill in the blanks by choosing the correct answer from the brackets : [2]

- (a) During electrolysis, the compoundin its molten state liberates reddish brown fumes at the anode. [NaCl/PbBr₂]

- (b) The ion which could be discharged most readily during electrolysis is [Fe²⁺/Cu²⁺]

2020

Q. 1. (a) Choose the correct answer from the options given below : [1]

(ii) The inert electrode used in the electrolysis of acidified water, is :

- (A) Nickel (B) Platinum
(C) Copper (D) Silver

(e) State one relevant reason for each of the following : [1]

(i) Graphite anode is preferred to platinum in the electrolysis of molten lead bromide.

(g) Give one word or a phrase for the following statements : [1]

(ii) Electrode used as cathode in electrorefining of impure copper.

Q. 2. (c) Choose the correct word which refers to the process of electrolysis from A to E, to match the description (i) to (iv) : [4]

A : Oxidation, B : Cathode, C : Anode, D : An electrolyte, E : Reduction

(i) Conducts electricity in aqueous or in molten state.

(ii) Loss of electron takes place at anode.

(iii) A reducing electrode.

(iv) Electrode connected to the positive end or terminal of the battery.

Q. 4. (a) Differentiate between the following pairs based on the information given in the brackets : [2]

(i) Conductor and electrolyte (conducting particles)

(ii) Cations and anions (formation from an atom)

Q. 6. (b) Identify the substance underlined in each of the following : [1]

(i) The electrode that increases in mass during the electro-refining of silver.

Q. 7. (c) An aqueous solution of nickel (II) sulphate was electrolyzed using nickel electrodes. Observe the diagram and answer the questions that follow :

(i) What do you observe at the cathode and anode respectively ?

(ii) Name the cation that remains as a spectator ion in the solution.

(iii) Which equation for the reaction at the anode is correct ?

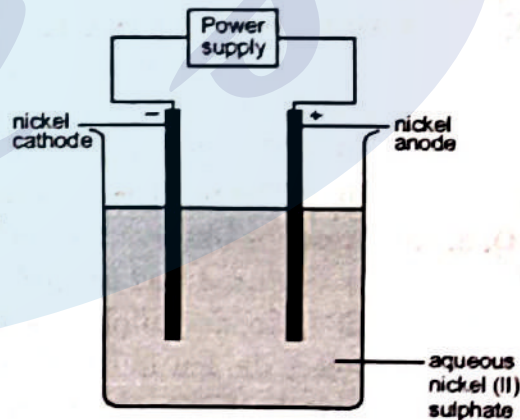
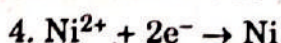
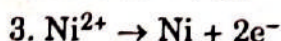
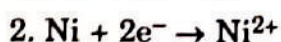
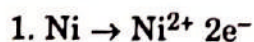

2019

Q. 1. (a) Choose the correct answer from the options given below : [1]

(i) An electrolyte which completely dissociates into ions is :

- (A) Alcohol (B) Carbonic acid
(C) Sucrose (D) Sodium hydroxide.

Q. 3. (a) Name the particles present in : [3]

(i) Strong electrolyte

(ii) Non-electrolyte

(iii) Weak electrolyte

2016

- Q. 1. (a)** Choose the correct answer from the options given below : [1]
 (iii) The electrolysis of acidified water is an example of :
 (A) Reduction (B) Oxidation
 (C) Redox reaction (D) Synthesis
- (e) State one relevant observation for the following : [1]
 (ii) At the anode, when molten lead bromide is electrolyzed using graphite electrodes.
- (g) Name the gas that is produced in the following case : [1]
 (iv) At the anode during the electrolysis of acidified water.
- (h) Fill up the blanks with the correct choice given in bracket : [1]
 (ii) Electrolysis of aqueous sodium chloride solution will form at the cathode.
 (hydrogen gas/sodium metal)

- Q. 2. (c)** Copy and complete the following table which refers to the conversion of ions to neutral particles. [4]

Conversion	Ionic Equation	Oxidation/Reduction
Chloride ion to chlorine molecule	(i)	(ii)
Lead (II) ion to lead	(iii)	(iv)

- Q. 3. (d)** For the electro-refining of copper : [2]
 (i) What is the cathode made up of ?
 (ii) Write the reaction that takes place at the anode.

2017

- Q. 1. (a)** Fill in the blank from the choices given in bracket : [1]
 (iii) When a metallic oxide is dissolved in water, the solution formed has a high concentration of ions. (H^+ , H_3O^+ , OH^-)
- (c) Identify the substance underlined, in each of the following cases : [2]
 (ii) The electrolyte used for electroplating an article with silver.
 (iii) The particles present in a liquid such as kerosene, that is a non electrolyte.
- Q. 3. (b)** State the observations at the anode and at the cathode during the electrolysis of : [4]
 (i) Fused lead bromide using graphite electrodes.
 (ii) Copper sulphate solution using copper electrodes.
- (c) Select the ion in each case, that would get selectively discharged from the aqueous mixture of the ions listed below : [2]
 (i) SO_4^{2-} , NO_3^- and OH^-
 (ii) Pb^{2+} , Ag^+ and Cu^{2+}

2016

- Q. 1. (a)** Fill in the blank with the choices given in bracket : [1]
 (ii) Electrovalent compounds have (high/low) melting points.
- (b) Choose the correct answer from the options given below : [1]
 (iv) The particles present in strong electrolytes are :
 (A) Only molecules (B) Mainly ions
 (C) Ions and molecules (D) Only atoms
- Q. 4. (c)** Write equations for the reactions taking place at the two electrodes (mentioning clearly the name of the electrode) during the electrolysis of : [4]
 (i) Acidified copper sulphate solution with copper electrodes.
 (ii) Molten lead bromide with inert electrodes.

- (d) (i) Name the product formed at the anode during the electrolysis of acidified water using platinum electrodes.
- (ii) Name the metallic ions that should be present in the electrolyte when an article made of copper is to be electroplated with silver. [2]

Q. 6. (d) Give reasons why : [3]

- (i) Sodium Chloride will conduct electricity only in fused or aqueous solution state.
- (ii) In the electroplating of an article with silver, the electrolyte sodium argentocyanide solution is preferred over silver nitrate solution.
- (iii) Although copper is a good conductor of electricity, it is a non-electrolyte.

Q. 7. (a) (iv) Write the equation for the reaction that occurs at the cathode during the extraction of aluminium by electrolysis.

- (v) Explain why it is preferable to use a number of graphite electrodes as anode instead of a single electrode, during the above electrolysis. [2]

2015

Q. 1. (d) State one relevant observation for the following :

- (v) At the Anode when aqueous copper sulphate solution is electrolysed using copper electrodes. [1]

(f) Give appropriate scientific reasons for the following statements :

- (iii) During electrolysis of molten lead bromide graphite anode is preferred to other electrodes.

- (iv) The electrical conductivity of acetic acid is less in comparison to the electrical conductivity of dilute sulphuric acid at a given concentration.

- (v) Electrolysis of molten lead bromide is considered to be a redox reaction. [3]

(g) (ii) Differentiate between the terms strong electrolyte and weak electrolyte. (stating and two differences) [2]

Q. 6. (b) (i) Copy and complete the following table :

	Anode	Electrolyte
Purification of copper		

[2]

- (ii) Write the equation taking place at the anode. [1]

2014

Q. 1. (a) Choose the correct answer from the options given below :

(iii) When fused lead bromide is electrolysed we observe :

- (A) a silver grey deposit at anode and a reddish brown deposit at cathode.
- (B) a silver grey deposit at cathode and a reddish brown deposit at anode.
- (C) a silver grey deposit at cathode and reddish brown fumes at anode.
- (D) silver grey fumes at anode and reddish brown fumes at cathode. [1]

(viii) The electrolyte used for electroplating an article with silver is :

- (A) silver nitrate solution (B) silver cyanide solution
- (C) sodium argentocyanide solution (D) nickel sulphate solution [1]

(c) Give one words or phrase for the following :

- (ii) Formation of ions from molecules. [1]

- (iii) Electrolytic deposition of a superior metal on a baser metal. [1]

Q. 2. (a) State your observation in the following case :

- (iii) At the cathode when acidified aqueous copper sulphate solution is electrolyzed with copper electrodes.

Q. 6. (b) (ii) Which electrode : anode or cathode is the oxidising electrode ? Why ? [1½]

2013

Q. 1. (c) State one appropriate observation for the following :

(v) Electricity is passed through molten lead bromide. [1]

(f) Choose the most appropriate answer from the following options :

(iv) Which of these will act as a non-electrolyte ?

(A) Liquid carbon tetrachloride

(B) Acetic acid

(C) Sodium hydroxide aqueous solution acid

(D) Potassium chloride aqueous solution. [1]

Q. 4. (a) Copper sulphate solution is electrolysed using copper electrodes.

Study the diagram given alongside and answer the questions that follows :

(i) Which electrode to your left or right is known as the oxidising electrode and why? [2]

(ii) Write the equation representing the reaction that occurs. [1]

(iii) State two appropriate observations for the above electrolysis reaction. [2]

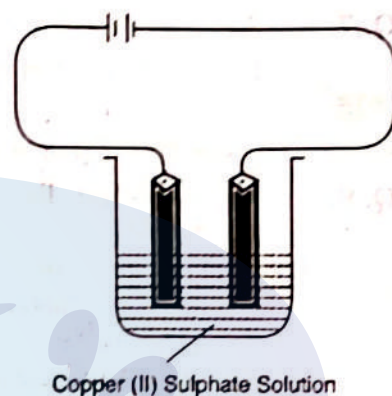

Metallurgy

2023

Q. 1. Choose the correct answer to the question from the given options. (Do not copy the questions, write the correct answer only).

(iii) The compound that is not an ore of aluminium :

[1]

(a) Cryolite

(b) Corundum

(c) Fluorspar

(d) Bauxite

Q. 2. (ii) The following sketch illustrates the process of conversion of Alumina to Aluminum :

[5]

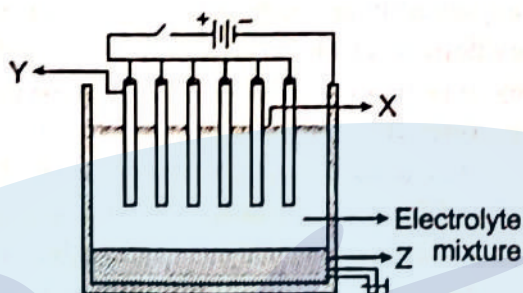

Study the diagram and answer the following :

- Name the constituent of the electrolyte mixture which has a divalent metal in it.
- Name the powdered substance 'X' sprinkled on the surface of the electrolyte mixture.
- What is the name of the process ?

- (d) Write the reactions taking place at the electrodes 'Y' (anodes) and 'Z' (cathode) respectively.
- Q. 2.** (iii) Fill in the blank with the choices given in the bracket : [1]
 (a) Metals are good..... [oxidizing agents/reducing agents]
- Q. 4.** (ii) Identify the alloy in each case from the given composition : [2]
 (a) aluminium, magnesium, manganese, copper
 (b) iron, nickel, chromium, carbon
- Q. 5.** (i) Write one use of the following alloys : [2]
 (a) Bronze
 (b) Fuse metal
- Q. 7.** (iv) Answer the following questions with reference to electro refining of copper : [3]
 (a) What is the anode made of?
 (b) What do you observe at the cathode?
 (c) Write the reaction taking place at the cathode.
- Q. 8.** (i) Arrange the following according to the instructions given in bracket : [1]
 (b) Cu^{2+} , Na^+ , Zn^{2+} , Ag^+ (The order of Preferential discharge at the cathode)
- (iv) Choose the answer from the list which fits in the description : [1]
 [CCl_4 , PbO , NaCl , CuO , NH_4Cl]
 (b) An amphoteric oxide.

2022

- Q. 1.** Choose the correct answers to the questions from the given options. (Do not copy the question. Write the correct answer only.)
- (i) The ore of Aluminium is : [1]
 (a) Calamine (b) Haematite
 (c) Magnetite (d) Cryolite
- (x) Substance which helps to lower the fusion point of the mixture in Hall Heroult Process : [1]
 (a) Coke (b) Concentrated sodium hydroxide
 (c) Fluorspar (d) Concentrated potassium hydroxide
- Q. 2.** (i) Define : [1]
 (b) Ores
- Q. 4.** (i) State the **relevant reason** for the following : [2]
 (a) Concentrated alkali is used for the concentration of bauxite ore.
 (b) Fused alumina is reduced to aluminium by electrolysis.
- (ii) State one use of the given alloys : [2]
 (a) Magnalium
 (b) Duralumin
- (iv) Identify the term for the following : [1]
 (a) The process used to purify Alumina by electrolytic reduction.
- Q. 5.** (ii) Select the right answer from the brackets and complete the statements : [2]
 In electrolysis of fused Alumina, the anode is made of (a) [gas carbon/graphite] and the product formed at cathode is (b) [oxygen/aluminium].
- Q. 6.** (ii) Give one word for the following statements : [2]
 (a) The compounds of various metals found in nature with earthly impurities.
 (b) A homogeneous mixture of two or more metals or a metal and a non-metal in specific ratios.

2020

- Q. 1.** (b) State one relevant observation for the following reaction : [1]
 (v) Sulphide ore is added to a tank containing oil and water, and then stirred or agitated with air.
- (g) Give one word or a phrase for the following statement : [1]
 (iii) The substance prepared by adding other metals to a base metal in appropriate proportions to obtain certain desirable properties.
- (h) Fill in the blank from the choices given in bracket : [1]
 (v) An alloy used to make statues is (bronze, brass, fuse metal)
- Q. 3.** (a) Baeyer's process is used to concentrate bauxite ore to alumina. [3]
 Give balanced chemical equations for the reaction taking place for its conversion from bauxite to alumina.
- Q. 7.** (b) Name the following elements : [2]
 (ii) A trivalent metal used to make light tools.
 (iii) A monovalent non-metal present in fluorspar.

2019

- Q. 1.** (a) Choose the correct answer from the options given below : [1]
 (iii) The reason for using Aluminium in the alloy duralumin is :
 (A) Aluminium is brittle. (B) Aluminium gives strength.
 (C) Aluminium brings lightness. (D) Aluminium lowers melting point.
- Q. 5.** (a) Give the chemical formula of : [3]
 (i) Bauxite
 (ii) Cryolite
 (iii) Sodium aluminate.
- (b) Answer the following questions based on the extraction of aluminium from alumina by Hall-Heroult's Process : [3]
 (i) What is the function of cryolite used along with alumina as the electrolyte ?
 (ii) Why is powdered coke sprinkled on top of the electrolyte ?
 (iii) Name the electrode, from which aluminium is collected.
- (c) Match the alloys given in column I to the uses given in column II : [4]
- | Column I | Column II |
|----------------------|-------------------------|
| (i) Duralumin | A. Electrical fuse |
| (ii) Solder | B. Surgical instruments |
| (iii) Brass | C. Aircraft body |
| (iv) Stainless Steel | D. Decorative articles |

2018

- Q. 1.** (a) Choose the correct answer from the options given below : [1]
 (v) The catalyst used in the Contact Process is :
 (A) Copper (B) Iron
 (C) Vanadium pentoxide (D) Manganese dioxide
- (b) Give one word or a phrase for the following statement : [1]
 (v) The process by which sulphide ore is concentrated.
- (h) Fill up the blank with the correct choice given in bracket : [1]
 (iv) The most common ore of iron is (calamine/haematite)
- Q. 4.** (d) Name the main component of the following alloys : [2]
 (i) Brass
 (ii) Duralumin

- Q. 5.** (b) (i) Name the most common ore of the metal aluminum from which the metal is extracted .Write the chemical formula of the ore.
- (ii) Name the process by which impure ore of aluminum gets purified by using concentrated solution of an alkali.
- (iii) Write the equation for the formation of aluminum at the cathode during the electrolysis of alumina. [4]

2017

- Q. 1.** (f) (ii) From the list of terms given, choose the most appropriate term to match the given description.
(calcination, roasting, pulverisation, smelting) [2½]
- Crushing of the ore into a fine powder.
 - Heating of the ore in the absence of air to a high temperature.

- Q. 7.** (a) Name the following : [4]
- The process of coating of iron with zinc.
 - An alloy of lead and tin that is used in electrical circuits.
 - An ore of zinc containing its sulphide.
 - A metal oxide that can be reduced by hydrogen.
- (b) Answer the following questions with respect to the electrolytic process in the extraction of aluminium : [3]
- Identify the components of the electrolyte other than pure alumina and the role played by each.
 - Explain why powdered coke is sprinkled over the electrolytic mixture.
- (c) Complete the following by selecting the correct option from the choices given : [3]
- The metal which does not react with water or dilute H_2SO_4 but reacts with concentrated H_2SO_4 is (Al/Cu/Zn/Fe).
 - The metal whose oxide, which is amphoteric , is reduced to metal by carbon reduction (Fe/Mg/Pb/Al)
 - The divalent metal whose oxide is reduced to metal by electrolysis of its fused salt is (Al/Na/Mg/K)

2016

- Q. 1.** (a) Fill in the blanks with the choices given in brackets : [1]
- Metals are good (oxidizing agents/reducing agents) because they are electron (acceptors/donors).
- (b) Choose the correct answer from the options given below : [1]
- The two main metals in *Bronze* are :
(A) Copper and zinc (B) Copper and lead
(C) Copper and nickel (D) Copper and tin
- (e) Identify the term/substance in following : [1]
- The method used to separate ore from gangue by preferential wetting.
- Q. 7.** (a) (i) Name the solution used to react with Bauxite as a first step in obtaining pure aluminium oxide, in the Baeyer's process.
- (ii) Write the equation for the reaction where the aluminium oxide for the electrolytic extraction of aluminium is obtained by heating aluminium hydroxide.
- (iii) Name the compound added to pure alumina to lower the fusion temperature during the electrolytic reduction of alumina.

2015

- Q. 1. (b) Choose the most appropriate answer for the following :
- (iii) This is not an alloy of copper :
- | | | |
|------------|---------------|-----|
| (A) Brass | (B) Bronze | |
| (C) Solder | (D) Duralumin | [1] |
- Q. 1. (c) Give appropriate scientific reason for the following statement :
- (i) Zinc oxide can be reduced to zinc by using carbon monoxide, but aluminium oxide cannot be reduced by a reducing agent. [1]
- Q. 5. (b) (i) For each of the substance listed below, describe the role played in the extraction of aluminium.
- | | | |
|---------------|----------------------|-----|
| (1) Cryolite | (2) Sodium hydroxide | |
| (3) Graphite. | | [3] |
- (ii) Explain why :
- (1) In the electrolysis of alumina using the Hall Heroult's Process the electrolyte is covered with powdered coke.
- (2) Iron sheets are coated with zinc during galvanization. [2]

2014

- Q. 1. (a) Choose the correct answer from the options given below :
- (iv) The main ore used for the extraction of iron is :
- | | | |
|---------------|--------------|-----|
| (A) Haematite | (B) Calamine | |
| (C) Bauxite | (D) Cryolite | [1] |
- (v) Heating an ore in a limited supply of air or in the absence of air at a temperature just below its melting point is known as :
- | | | |
|-----------------|---------------------|-----|
| (A) smelting | (B) ore dressing | |
| (C) calcination | (D) bessemerisation | [1] |
- (ix) Aluminium powder is used in thermite welding because :
- | | | |
|-----------------------------------|------------------------------------|-----|
| (A) it is a strong reducing agent | (B) it is a strong oxidising agent | |
| (C) it is corrosion resistant | (D) it is a good conductor of heat | [1] |
- Q. 3. (b) State the main components of the following alloys :
- | | | |
|---------------|----------------|-----|
| (i) Brass. | (ii) Duralumin | |
| (iii) Bronze. | | [3] |
- Q. 5. (a) Name the following :
- (i) The property possessed by metals by which they can be beaten into sheets.
- (ii) A compound added to lower the fusion temperature of electrolytic bath in the extraction of aluminium.
- (iii) The ore of zinc containing its sulphide. [3]

2013

- Q. 1. (f) Choose the most appropriate answer from the following options :
- (v) Which one of the following will not produce an acid when made to react with water ?
- | | | |
|----------------------|----------------------|-----|
| (A) Carbon monoxide | (B) Carbon dioxide | |
| (C) Nitrogen dioxide | (D) Sulphur trioxide | [1] |
- (vi) Identify the metallic oxide which is amphoteric in nature :
- | | | |
|-------------------|----------------------|-----|
| (A) Calcium oxide | (B) Barium oxide | |
| (C) Zinc oxide | (D) Copper(II) oxide | [1] |
- (x) The metals zinc and tin are present in the alloy :
- | | | |
|------------|---------------|-----|
| (A) Solder | (B) Brass | |
| (C) Bronze | (D) Duralumin | [1] |

Q. 4. (b)

	X	Y
Normal Electronic Configuration	2, 8, 7	2, 8, 2
Nature of oxide	Dissolves in water and turns blue litmus red	Very low solubility in water. Dissolves in hydrochloric acid
Tendency for oxidising and reducing reactions	Tends to oxidise elements and compounds	Tends to act as a reducing agent
Electrical and Thermal conductivity	Very poor electrical conductor Poor thermal conductivity	Good Electrical conductor Good Thermal conductor
Tendency to form alloys and amalgams	No tendency to form alloys	Forms alloys

Using the information above, complete the following :

- is the metallic element.
- Metal atoms tend to have maximum of electrons in the outermost energy level.
- Non-metallic elements tends to form oxides while metals tend to form oxides.
- Non-metallic elements tend to be conductors of heat and electricity.
- Metals tend to electrons and act as agents in their reactions with elements and compounds. [5]

Q. 5. (c) The following questions relate to the extraction of aluminium by electrolysis :

- Name the other aluminium containing compound added to alumina and state its significance.
- Give the equation for the reaction that takes place at the cathode.
- Explain why is it necessary to renew the anode periodically. [4]

CHAPTER 8

Hydrogen Chloride

2023

Q. 1. Choose the correct answer to the question from the given options. (Do not copy the questions, write the correct answer only).

(viii) In the laboratory preparation, HCl gas is dried by passing through : [1]

- | | |
|---------------------------|---------------------------------|
| (a) dilute nitric acid | (b) concentrated sulphuric acid |
| (c) dilute sulphuric acid | (d) acidified water |

Q. 4. (i) State a relevant for the following : [1]

- (a) Hydrogen chloride gas cannot be dried over quick lime.

Q. 6. (iii) Choose the substances given in the box below to answer the following questions : [2]

Iron	Magnesium	Zinc	Sodium sulphide
Lead	Ferric chloride	Copper	Ferrous sulphate

- (a) The metal that will not produce hydrogen gas when reacted with dilute

- (b) The compound that will produce sulphur dioxide gas when reacted with dilute HCl.

Q. 8. (iii) Convert the following reactions into a balanced chemical equation : [1]
(c) Ferrous sulphide to hydrogen sulphide using hydrochloric acid.

2022

Q. 1. Choose the correct answers to the questions from the given options. (Do not copy the question. Write the correct answer only.)

(ii) Hydrogen chloride gas is not collected over water, as : [1]

- (a) It is highly soluble in water. (b) It is less soluble in water.
(c) It is lighter than air. (d) It is heavier than air.

(vii) The metallic oxide which when reacts with HCl forms salt and water : [1]

- (a) Carbon monoxide (b) Nitrous oxide
(c) Ammonium hydroxide (d) Sodium oxide

Q. 4. (iv) Identify the term for the following : [1]

- (b) The experiment used to demonstrate the high solubility of HCl gas.

Q. 5. (i) Write the balanced chemical equation for the following : [2]

- (a) Action of heat on manganese dioxide and concentrated hydrochloric acid.
(b) Zinc reacts with dilute hydrochloric acid to form zinc chloride.

2020

Q. 1. (e) State one relevant reason for each of the following : [1]

- (v) Hydrogen chloride gas fumes in moist air.

Q. 3. (b) Complete the following by selecting the correct option from the choices given : [2]

- (ii) The indicator which does not change colour on passage of HCl gas is
(methyl orange, moist blue litmus, phenolphthalein)
(iii) The acid which cannot act as an oxidizing agent is
(conc. H_2SO_4 , conc. HNO_3 , conc. HCl)

Q. 4. (c) Hydrogen chloride gas is prepared in the laboratory using concentrated sulphuric acid and sodium chloride. Answer the questions that follow based on this reaction : [4]

- (i) Give the balanced chemical equation for the reaction with suitable conditions(s) if any.
(ii) Why is concentrated sulphuric acid used instead of concentrated nitric acid ?
(iii) How is the gas collected ?
(iv) Name the drying agent not used for drying the gas.

2019

Q. 1. (a) Choose the correct answer from the options given below : [1]

- (iv) The drying agent used to dry HCl gas is :

- (A) Conc. H_2SO_4 (B) ZnO
(C) Al_2O_3 (D) CaO.

2018

Q. 1. (f) Give a reason for the following : [1]

- (v) Conductivity of dilute hydrochloric acid is greater than that of acetic acid.

(h) Fill up the blanks with the correct choice given in bracket : [1]

- (iii) Dry hydrogen chloride gas can be collected by displacement of air.
(downward/upward)

Q. 3. (b) (i) Name the acid used for the preparation of hydrogen chloride gas in the laboratory. Why is this particular acid preferred to other acids ?

- (ii) Write the balanced chemical equation for the laboratory preparation of hydrogen chloride gas. [3]
- (c) For the preparation of hydrochloric acid in the laboratory : [2]
- (i) Why is direct absorption of hydrogen chloride gas in water not feasible?
- (ii) What arrangement is done to dissolve hydrogen chloride gas in water?

2017

- Q. 1. (e) State one relevant observation for the following reaction : [1]
- (ii) Action of dilute Hydrochloric acid on iron (II) sulphide.
- Q. 4. (a) Certain blank spaces are left in the following table and these are labelled as A and B. Identify each of them. [2½]

Lab. Preparation of	Reactants used	Products formed	Drying agent	Method of Collection
(i) HCl gas	NaCl + H ₂ SO ₄	A	cons. H ₂ SO ₄	B

2016

- Q. 1. (b) Choose the correct answer from the options given below : [1]
- (v) The aim of the Fountain Experiment is to prove that :
- (A) HCl turns blue litmus red (B) HCl is denser than air
(C) HCl is highly soluble in water (D) HCl fumes in moist air.
- (c) Write balanced chemical equation for the following : [1]
- (iii) Action of Hydrochloric acid on sodium bicarbonate.
- (d) State your observations when : [3]
- (i) Dilute Hydrochloric acid is added to Lead nitrate solution and the mixture is heated.
- (iv) Dilute Hydrochloric acid is added to Copper carbonate.
- (v) Dilute Hydrochloric acid is added to Sodium thiosulphate.

2015

- Q. 1. (e) Identify the acid which match the following description :
- (i) The acid which is used in the preparation of a non-volatile acid. [1]
- (v) The acid on mixing with silver nitrate solution produces a white precipitate which is soluble in excess ammonium hydroxide. [1]
- Q. 7. (a) The following questions are pertaining to the laboratory preparation of hydrogen chloride gas :
- (i) Write the equation for its preparation mentioning the condition required. [1]
- (ii) Name the drying agent used and justify your choice. [2]
- (iii) State a safety precaution you would take during the preparation of hydrochloric acid. [1]

2014

- Q. 1. (b) Fill in the blank from the choice given within bracket :
- (iii) Quicklime is not used to dry HCl gas because (CaO is alkaline, CaO is acidic, CaO is neutral). [1]
- (e) Write balanced equation for the following :
- (iv) Action of dilute hydrochloric acid on sodium sulphide.

Q. 2. (a) State your observation in each of the following cases :

- (i) When dilute hydrochloric acid is added to sodium carbonate crystals. [1]
- (v) When moist starch iodide paper is introduced into chlorine gas. [1]

(b) Study the figure given below and answer the questions that follow :

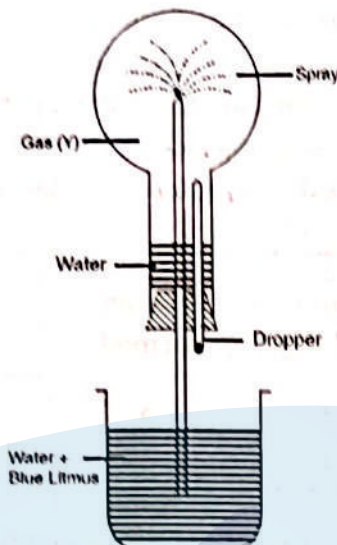

- (i) Identify the gas Y.
- (ii) What property of gas Y does this experiment demonstrate?
- (iii) Name another gas which has the same property and can be demonstrated through this experiment. [3]

2013

Q. 1. (b) Identify the gas evolved in the following reactions when :

- (ii) Potassium sulphite is treated with dilute hydrochloric acid. [1]
- (v) concentrated hydrochloric acid is made to react with manganese dioxide. [1]

(c) State one appropriate observation for each of the following :

- (ii) Copper sulphide is treated with dilute hydrochloric acid. [1]
- (iv) A few drops of dilute hydrochloric acid are added to silver nitrate solution, followed by addition of ammonium hydroxide solution. [1]

(e) Give a chemical test to distinguish between the following pairs of compounds :

- (i) Sodium chloride solution and sodium nitrate solution. [1]
- (ii) Hydrogen chloride gas and hydrogen sulphide gas. [1]

Q. 7. (b) Identify the following substance which are underlined :

- (iii) A gas which does not conduct electricity in the liquid state but conducts electricity when dissolved in water. [1]

Ammonia**2023****Q. 2. (iv) State the terms/process for the following :** [1]

(c) The name of the process by which Ammonia is manufactured on a large scale.

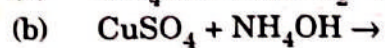
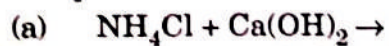
Q. 3. (iv) Complete and balance the following equations : [2]Pati's

- Q. 4.** (i) State a relevant for the following : [1]
 (b) Ammonia gas is collected over water.
 (iv) The following questions are pertaining to the laboratory preparation of Ammonia gas from Magnesium nitride : [3]
 (a) Write a balanced chemical equation for its preparation.
 (b) Why is this method seldom used ?
 (c) How do you identify the gas formed ?
- Q. 6.** (iv) State one relevant observation for each of the following : [2]
 (b) Burning of ammonia in excess of oxygen.
 (c) Dry ammonia gas is passed over heated PbO.
- Q. 8.** (iii) Convert the following reactions into a balanced chemical equation : [1]
 (a) Ammonia to nitric oxide using oxygen and platinum catalyst.

2022

- Q. 1.** Choose the correct answers to the questions from the given options. (Do not copy the question. Write the correct answer only.)
 (iii) An aqueous solution of ammonia is : [1]
 (a) Neutral (b) Acidic
 (c) Basic (d) Amphoteric
- Q. 3.** (i) State the following : [1]
 (a) A compound formed when excess ammonia gas reacts with chlorine.
 (ii) Identify the gas **P** in the reaction given below : [1]
 (a) A compound reacts with an acid to form gas **P** which has no effect on acidified $K_2Cr_2O_7$ solution but turns lime water milky.
 (iii) State the **observation** for the following : [2]
 (a) Dry ammonia gas reacts with oxygen in the presence of a catalyst.
 (b) Excess chlorine gas reacts with ammonia gas.
- Q. 4.** (iii) Complete the table given below which refers to the Laboratory preparation of Ammonia gas : [3]

Laboratory preparation	Reactants used	Products formed	Drying agent	Method of collection
Ammonia gas	(a)	Calcium chloride + water + ammonia	(b)	(c)

2020

- Q. 1.** (c) Write a balanced chemical equation for each of the following : [1]
 (ii) Reaction of excess ammonia with chlorine.

2019

- Q. 1.** (b) Fill in the blank with the choices given in bracket : [1]
 (iii) Ammonia reacts with excess chlorine to form.....
 (nitrogen/nitrogen trichloride/ammonium chloride)
- Q. 7.** (b) Study the flow chart given and give balanced equations to represent the reactions A, B and C : [3]



2018

- Q. 3.** (a) (i) Write the balanced chemical equation to prepare ammonia gas in the laboratory by using an alkali. (ii) State why concentrated sulphuric acid is not used for drying ammonia gas. (iii) Why is ammonia gas not collected over water? [3]

2017

- Q. 1.** (d) Write a balanced chemical equation for each of the following : [2]
 (ii) Reaction of Ammonia with heated copper oxide.
 (v) Laboratory preparation of ammonia from ammonium chloride.
 (e) State one relevant observation for the following reaction : [1]
 (iv) Burning of ammonia in air.
Q. 4. (a) Certain blank spaces are left in the following table and these are labelled as C, D and E. Identify each of them. [2½]

Lab. Preparation of	Reactants used	Products formed	Drying agent	Method of Collection
(ii) NH ₃ gas	C	Mg(OH) ₂ NH ₃	D	E

2016

- Q. 1.** (c) Write balanced chemical equation for the following : [1]
 (i) Action of warm water on AlN.
Q. 6. (a) Name the gas evolved when the following mixtures are heated : [2]
 (i) Calcium hydroxide and Ammonium Chloride.
 (ii) Sodium Nitrite and Ammonium Chloride.
 (b) Write balanced chemical equations for each of the following : [2]
 (i) When excess of ammonia is treated with chlorine.
 (ii) An equation to illustrate the reducing nature of ammonia.

2015

- Q. 1.** (d) State one relevant observation for the following : [1]
 (iv) When ammonia gas is burnt in an atmosphere of excess oxygen.
Q. 4. (c) Give balanced chemical equations for each of the following : [3]
 (i) Lab preparation of ammonia using an ammonium salt.
 (ii) Reaction of ammonia with excess chlorine.
 (iii) Reaction of ammonia with sulphuric acid.

2014

- Q. 1.** (b) Fill in the blank from the choice given within bracket : [1]
 (iv) Ammonia gas is collected by (an upward displacements of air, a downward displacement of water, a downward displacement of air)
 (e) Write balanced equation for the following : [1]
 (ii) Action of warm water on magnesium nitride.
Q. 2. (a) State your observation in the following case : [1]
 (iv) When calcium hydroxide is heated with ammonium chloride crystals.
 (c) (i) Name the other ion formed when ammonia dissolves in water. [1]
 (ii) Give one test that can be used to detect the presence of the ion produced. [2]

2013

- Q. 1.** (c) State one appropriate observation for the following : [1]
 (iii) Excess of chlorine gas is reacted with ammonia gas.

(f) Choose the most appropriate answer from the following options :

(viii) Nitrogen gas can be obtained by heating :

(A) Ammonium nitrate

(B) Ammonium nitrite

(C) Magnesium nitride

(D) Ammonium chloride

[1]

Q. 5. (a) Give balanced equation for the following :

(i) Reducing of hot Copper (II) oxide to copper using ammonia gas.

[1]

(b) Copy and complete the following table relating to important industrial process :

Name of the process	Temperature	Catalyst	Equation for the catalyzed reaction
Haber's process			

[3]

Q. 7. (b) Identify the following substance which is underlined :

(i) An alkaline gas which produces dense white fumes when reacted with hydrogen chloride gas.

[1]



Nitric acid

2023

- Q. 3.** (iv) Complete and balance the following equation : [1]
(c) $\text{Cu} + \text{Conc. HNO}_3 \rightarrow$

2022

- Q. 1.** Choose the correct answers to the questions from the given options. (Do not copy the question. Write the correct answer only.) [1]
(v) The gas formed, when calcium bisulphite reacts with dilute HNO_3 : [1]
(a) Sulphur trioxide (b) Hydrogen
(c) Sulphur dioxide (d) Hydrogen sulphide
- Q. 3.** (ii) Identify the gas **Q** in the reaction given below : [1]
(b) A metallic nitrate reacts on heating gives oxygen gas along with a coloured gas **Q**.
- (iii) State the **observation** for the following : [1]
(c) Carbon reacts with hot concentrated nitric acid.
- (iv) Write **balanced equation** for the following conversion : [1]
(b) Ferric nitrate from ferric hydroxide and nitric acid.
- Q. 5.** (iv) Study the diagram, which shows the Brown Ring Test and answer the questions given below : [3]

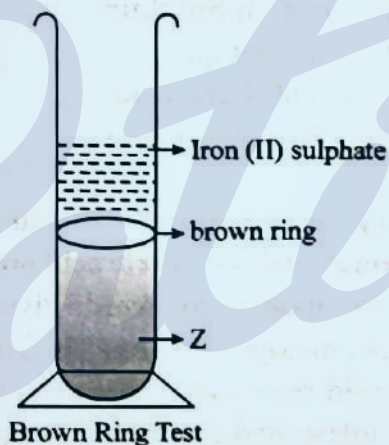

- (a) Which ion is determined by Brown Ring Test?
 (b) Why is freshly prepared iron[II] sulphate used in the test?
 (c) Name the substance Z.
- Q. 6.** (i) Distinguish between the following as directed : [1]
 (b) Lead salt solution and zinc salt solution.
 [using NH_4OH solution in excess]
 (iii) Identify **the acid** in each case : [1]
 (c) The acid formed when potassium nitrate reacts with a least volatile acid.

2020

- Q. 1.** (b) State one relevant observation for each of the following reactions : [1]
 (i) Action of concentrated nitric acid on copper.
 (c) Write a balanced chemical equation for each of the following : [1]
 (i) Reaction of carbon powder and concentrated nitric acid.
 (e) State one relevant reason for each of the following : [1]
 (iv) Concentrated nitric acid appears yellow, when it is left for a while in a glass bottle.
- Q. 6.** (b) Identify the substance underlined in each of the following : [1]
 (iii) The catalyst used to oxidize ammonia into nitric oxide.

2019

- Q. 4.** (a) Complete the following equations : [2]
 (i) $\text{S} + \text{conc. HNO}_3 \rightarrow$
 (iii) $\text{Cu} + \text{dil. HNO}_3 \rightarrow$

2018

- Q. 1.** (g) Name the gas that is produced in each of the following cases : [2]
 (i) Sulphur is oxidized by concentrated nitric acid.
 (iii) Action of cold and dilute nitric acid on copper.
- Q. 7.** (c) (i) What is the type of salt formed when the reactants are heated at a suitable temperature for the preparation of Nitric acid?
 (ii) State why for the preparation of Nitric acid, the complete apparatus is made up of glass. [2]

2017

- Q. 1.** (d) Write a balanced chemical equation for the following : [1]
 (i) Action of cold and dilute Nitric acid on Copper.
- Q. 6.** (a) Give a balanced chemical equation for each of the following : [4]
 (i) Action of conc. Nitric acid on Sulphur.
 (ii) Catalytic oxidation of Ammonia.
 (iii) Laboratory preparation of Nitric acid.
 (iv) Reaction of Ammonia with Nitric acid.

2016

- Q. 1.** (c) Write balanced chemical equation of the following : [1]
 (ii) Action of hot and concentrated Nitric acid on copper.
- Q. 3.** (d) Fill in the blanks using the appropriate words given below : [2]
 (Sulphur dioxide, Nitrogen dioxide, Nitric oxide, Sulphuric acid)
 (i) Cold, dilute nitric acid reacts with copper to give
 (ii) Hot, concentrated nitric acid reacts with sulphur to form

2015

- Q. 1. (e)** Identify the acid which match the following description :
- (iii) The acid which is prepared by catalytic oxidation of ammonia.
- Q. 6. (c)** Explain the following :
- (i) Dilute nitric acid is generally considered a typical acid but not so in its reaction with metals.
- (ii) Contrated nitric acid appears yellow when it is left standing in a glass bottle.
- (iii) An all glass apparatus is used in the laboratory preparation of nitric acid. [3]

2014

- Q. 1. (b)** Fill in the blank from the choice given within bracket :
- (v) Cold, dilute nitric acid reacts with copper to form (Hydrogen, nitrogen dioxide, nitric oxide). [1]
- (e) Write balanced equation for the following :
- (i) Action of heat on a mixture of copper and concentrated nitric acid. [1]
- Q. 3. (a)** State the condition required for the following reaction to take place :
- (iii) Catalytic oxidation of ammonia to nitric oxide. [1]
- (c) Give balanced equation for the following :
- (i) Laboratory preparation of nitric acid. [1]

2013

- Q. 1. (b)** Identify the gas evolved in the following reactions when :
- (iii) Sulphur is treated with concentrated nitric acid. [1]
- (iv) a few crystals of KNO_3 are heated in hard glass test tube. [1]
- (e) Give a chemical test to distinguish between the following pair of compound :
- (iv) Calcium nitrate solution and zinc nitrate solution. [1]
- Q. 5. (a)** Give balanced equation for the following :
- (ii) Oxidation of carbon with concentrated nitric acid. [1]

Sulphuric acid

2023

Q. 1. Choose the correct answer to the question from the given options. (Do not copy the questions, write the correct answer only).

(x) The salt formed when concentrated sulphuric acid reacts with KNO_3 above 200°C : [1]

(a) K_2SO_4

(b) K_2SO_3

(c) KHSO_4

(d) KHSO_3

(xi) The property exhibited by concentrated sulphuric acid when it is used to prepare hydrogen chloride gas from potassium chloride : [1]

(a) Dehydrating property

(b) Drying property

(c) Oxidizing property

(d) Non-volatile acid property

Q. 8. (iii) Convert the following reactions into a balanced chemical equation : [1]

(b) Sodium hydroxide to sodium sulphate using sulphuric acid.



2022

- Q. 1. Choose the correct answers to the questions from the given options. (Do not copy the question. Write the correct answer only.)
- (iv) The acid which is *least* volatile is : [1]
(a) Hydrochloric acid (b) Nitric acid
(c) Dilute sulphuric acid (d) Concentrated sulphuric acid
- (viii) Vanadium pentoxide is used as a *catalyst* in the preparation of : [1]
(a) Nitrogen gas (b) Nitrogen dioxide gas
(c) Sulphur trioxide gas (d) Carbon dioxide gas
- Q. 3. (i) State the following : [1]
(b) A substance added to water, to manufacture sulphuric acid in Contact process.
- (iv) Write **balanced equation** for the following conversions : [2]
(a) Carbon from cane sugar and concentrated sulphuric acid.
(c) Ammonium sulphate from ammonium hydroxide and sulphuric acid.
- Q. 4. (iv) Identify the term for the following : [1]
(c) The chemical property of sulphuric acid to form two types of salts with an alkali.
- Q. 6. (i) Distinguish between the following as directed : [1]
(a) Sodium sulphite solution and sodium sulphate solution.
[using dilute H_2SO_4]
- (iii) Identify the **acid** in each case : [2]
(a) The acid formed when Sulphur reacts with concentrated nitric acid.
(b) An acid, which on adding to lead nitrate solution produces a white precipitate which is soluble on heating.

2020

- Q. 1. (a) Choose the correct answer from the options given below : [1]
(iv) The acid which can produce carbon from cane sugar, is :
(A) Concentrated Hydrochloric acid (B) Concentrated Nitric acid
(C) Concentrated Sulphuric acid (D) Concentrated Acetic acid

2019

- Q. 1. (b) Fill in the blank with the choices given in bracket : [1]
(ii) When sodium chloride is heated with concentrated sulphuric acid below $200^\circ C$, one of the products formed is..... .
(sodium hydrogen sulphate/sodium sulphate/chlorine)
- Q. 4. (a) Complete the following equation : [1]
(ii) $C + \text{conc. } H_2SO_4 \rightarrow$

2018

- Q. 1. (c) Write a balanced chemical equation for the following : [1]
(i) Action of concentrated sulphuric acid on carbon.
- Q. 7. (d) Which property of sulphuric acid is shown by the reaction of concentrated sulphuric acid with : [2]
(i) Ethanol?
(ii) Carbon?

2017

- Q. 1. (d) Write a balanced chemical equation for the following : [1]
(iv) Action of concentrated sulphuric acid on Sulphur.

- (e) State one relevant observation for the following reaction : [1]
 (v) Action of concentrated Sulphuric acid on hydrated copper sulphate.

- Q. 4.** (b) Write balanced chemical equation to show : [1]
 (i) The oxidizing action of conc. Sulphuric acid on Carbon.
 (c) Write balanced chemical equations to show how SO_3 is converted to Sulphuric acid in the contact process. [2]

2016

- Q. 1.** (c) Write balanced chemical equation for the following : [1]
 (iv) Action of dilute Sulphuric acid on Sodium Sulphite.
 (d) State your observations when : [2]
 (ii) Barium chloride solution is mixed with Sodium Sulphate Solution.
 (iii) Concentrated Sulphuric acid is added to Sugar Crystals.

- Q. 6.** (c) A, B, C and D summarize the properties of sulphuric acid depending on whether it is dilute or concentrated. [3]

A = Typical acid property

B = Non volatile acid

C = Oxidizing agent

D = Dehydrating agent

Choose the property (A, B, C or D) depending on which is relevant to each of the following :

- (i) Preparation of Hydrogen chloride gas.
 (ii) Preparation of Copper sulphate from copper oxide.
 (iii) Action of conc. Sulphuric acid on Sulphur.

2015

- Q. 1.** (e) Identify the acid which matches the following description :
 (ii) The acid which produces sugar charcoal from sugar. [1]
 (iv) The acid on mixing with lead nitrate solution produces a white precipitate which is insoluble even on heating. [1]

- Q. 6.** (a) (i) Give balanced chemical equations for the action of sulphuric acid on each of the following :
 (1) Potassium hydrogen carbonate.
 (2) Sulphur. [2]
 (ii) In the contact process for the manufacture of sulphuric acid give the equations for the conversion of sulphur trioxide to sulphuric acid. [2]

2014

- Q. 1.** (e) Write balanced equation for the following :
 (iii) Action of concentrated sulphuric acid on carbon. [1]
 (f) Distinguish between the following pairs of compounds using the test given within brackets :
 (iii) Sodium nitrate and sodium sulphite (using dilute sulphuric acid) [1]
 (iv) Dilute sulphuric acid and dilute hydrochloric acid (using barium chloride solution). [1]

- Q. 3.** (a) State the condition required for the following reaction to take place :
 (iv) Any two conditions for the conversion of sulphur dioxide to sulphur trioxide. [2]

- Q. 5.** (b) Give one equation each to show the following properties of sulphuric acid :
 (i) Dehydrating property.

- (ii) Acidic nature.
(iii) As a non-volatile acid. [3]

2013

- Q. 1. (c)** State one appropriate observation for the following :
- (i) Concentrated sulphuric acid is added drop wise to a crystal of hydrated copper sulphate. [1]
- (e) Give a chemical test to distinguish between pair of compound.
- (v) Carbon dioxide gas and sulphur gas. [1]
- (f) Choose the most appropriate answer from the following options :
- (vii) In the given equation identify the role played by concentrated sulphuric acid
- $$\text{S} + 2\text{H}_2\text{SO}_4 \rightarrow 3\text{SO}_2 + 2\text{H}_2\text{O}$$
- (A) Non-volatile acid (B) Oxidising agent
(B) Dehydrating agent (D) None of the above [1]
- Q. 5. (a)** Give balanced equation for the following :
- (iii) Dehydration of concentrated sulphuric acid with sugar crystals. [1]
- Q. 7. (b)** Identify the following substance which are underlined :
- (iv) A dilute mineral acid which forms a white precipitate when treated with barium chloride solution. [1]

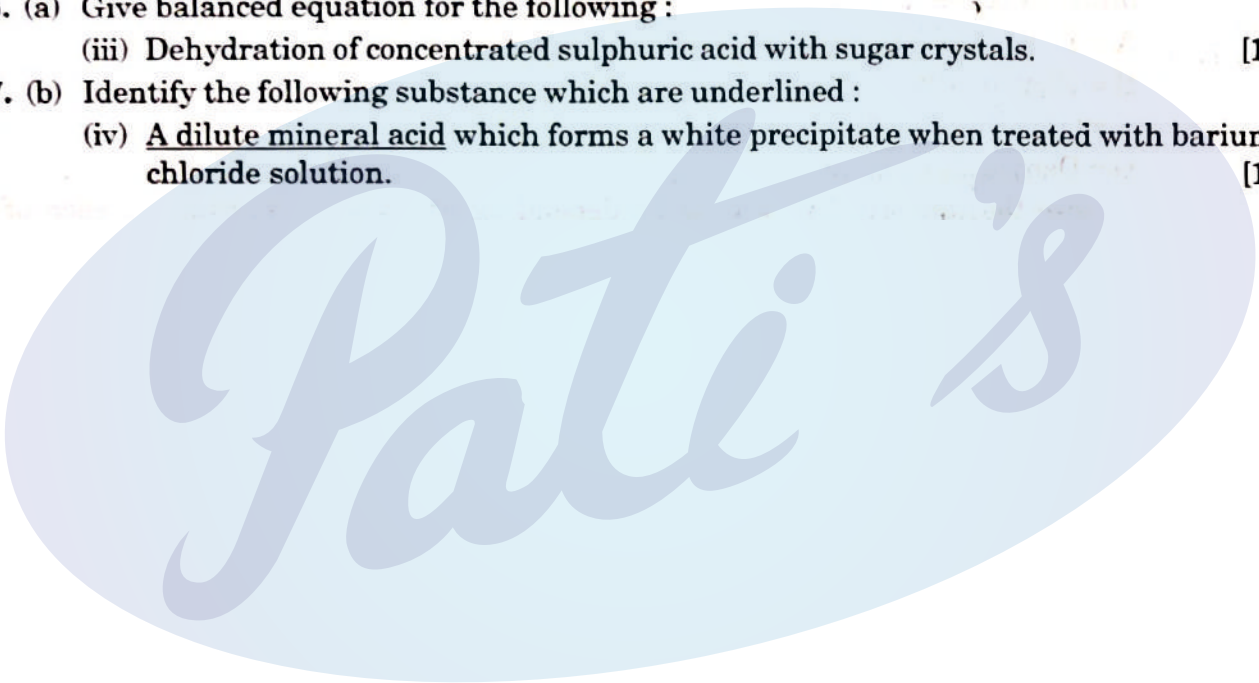

Organic Chemistry

2023

Q. 1. Choose the correct answer to the question from the given options. (Do not copy the questions, write the correct answer only).

(iv) The vapour density of CH_3OH is..... .
(At. Wt. C = 12, H = 1, O = 16) [1]

- (a) 32 (b) 18
(c) 16 (d) 34

(vii) An example of a cyclic organic compound is : [1]

- (a) Propene (b) Pentene
(c) Butene (d) Benzene

(xii) The hydrocarbon formed when sodium propanoate and soda lime are heated together : [1]

- (a) Methane (b) Ethane
(c) Ethene (d) Propane

(xiv) The general formula of hydrocarbons with single covalent bonds is : [1]

- (a) $\text{C}_n\text{H}_{2n+2}$ (b) C_nH_{2n}
(c) $\text{C}_n\text{H}_{2n-2}$ (d) $\text{C}_n\text{H}_{2n-6}$

Q. 2. (iii) Fill in the blank with the choices given in the bracket : [2]

- (b) Non-polar covalent compounds are[good/bad] conductors of heat and electricity.
(e) Conversion of ethene to ethane is an example of.....[hydration/hydrogenation]

(iv) State the terms/process for the following : [1]

(b) Tendency of an element to form chains of identical atoms.

(v) (a) Give the structural formula of the following organic compounds : [5]

1. 2-chlorobutane

2. Methanal

3. But-2-yne

(b) Give the IUPAC name of the following organic compounds :

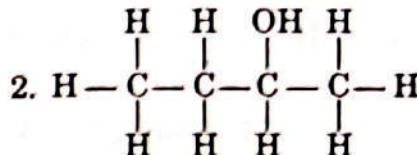
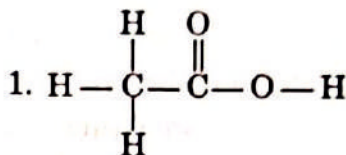

(iii) Give a balanced chemical equation for the following conversions with conditions : [3]

Ethene from ethanol

from calcium carbide

from methane

Q. 7. (i) Name the [2]

(a) Organic compounds having the same molecular formula but different structural formula.

(b) Group of organic compounds where the carbon atoms follow a regular structural pattern, successive compounds differ by CH_2 .

Q. 8. (i) Arrange the following according to the instructions given in brackets.

(a) C_2H_2 , C_3H_6 , CH_4 , C_2H_4 (In the increasing order of the molecular weight)

2022

Q. 1. Choose the correct answers to the questions from the given options. (Do not copy the question. Write the correct answer only.)

(vi) The IUPAC name of formic acid : [1]

(a) Propanoic acid

(b) Methanoic acid

(c) Ethanoic acid

(d) Butanoic acid

(ix) The Catalyst used for the conversion of Ethene to Ethane : [1]

(a) Iron

(b) Nickel

(c) Cobalt

(d) Molybdenum

Q. 2. (i) Define : [1]

(a) Isomerism

(ii) Name the following : [2]

(a) The property by which carbon links with itself to form a long chain.

(b) The saturated hydrocarbons having general formula $\text{C}_n\text{H}_{2n-2}$

(iii) Draw the structural diagram of : [3]

(a) pentanal

(b) propanol

(c) 2-butene

(iv) Complete and balance the following chemical equations : [3]

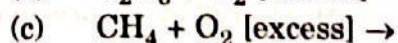
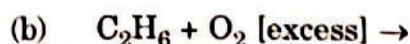
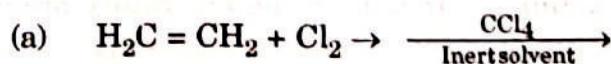

Q. 5. (iii) Give the IUPAC name for the following :

[3]

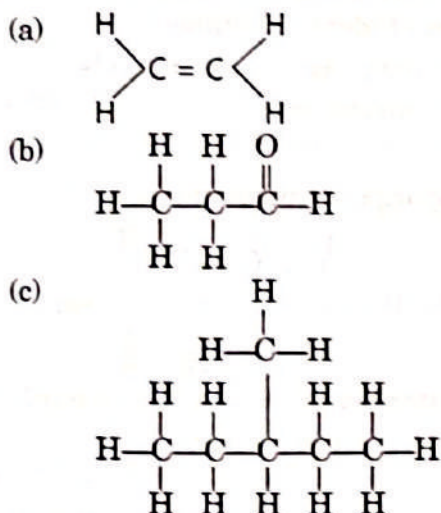

Q. 6. (iv) Match column A with column B :

[3]

Name (A)	Functional group (B)
1. Aldehyde	(a) —OH
2. Carboxylic acids	(b) —CHO
3. Alcohol	(c) —COOH

2020

Q. 1. (a) Choose the correct answer from the options given below :

[1]

(v) The organic compound having a triple carbon-carbon covalent bond, is :

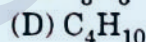
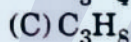
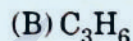
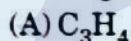

(b) State one relevant observation for each of the following reactions :

[1]

(iii) A piece of sodium metal is put into ethanol at room temperature.

(c) Write a balanced chemical equation for each of the following :

[2]

(iv) Producing ethane from bromo ethane using Zn/Cu couple in alcohol.

(v) Complete combustion of ethane.

(d) (i) Draw the structure for each of the following :

[5]

1. 2,2 dimethyl pentane

2. methanol

3. Iso propane

(ii) Write the IUPAC name for the following compounds :

1. acetaldehyde

2. acetylene

(e) State one relevant reason for each of the following :

[1]

(ii) Soda lime is preferred to sodium hydroxide in the laboratory preparation of methane.

(g) Give one word or a phrase for the following statements :

[1]

(v) The reaction in which carboxylic acid reacts with alcohol in the presence of conc. H_2SO_4 to form a substance having a fruity smell.

Q. 4. (b) Draw the structures of isomers of pentane. [3]

Q. 6. (c) Copy and complete the following paragraph using the options given in brackets : [4]

Alkenes are a homologous series of (i) (saturated / unsaturated) hydrocarbons characterized by the general formula (ii) (C_nH_{2n+2} / C_nH_{2n}). Alkenes undergo (iii) (addition / substitution) reactions and also undergo (iv) (hydrogenation / dehydrogenation) to form alkanes.

2019

Q. 1. (a) Choose the correct answer from the options given below : [1]

(v) A hydrocarbon which is a greenhouse gas is :

- (A) Acetylene (B) Ethylene
(C) Ethane (D) Methane

(b) Fill in the blanks with the choices given in brackets : [2]

(i) Conversion of ethanol to ethene by the action of concentrated sulphuric acid is an example of..... (dehydration/dehydrogenation/dehydrohalogenation)

(iv) Substitution reactions are characteristic reactions of..... (alkynes/alkenes/alkanes)

(f) (i) Give the IUPAC name of the following organic compounds : [5]

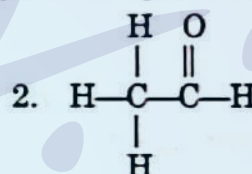
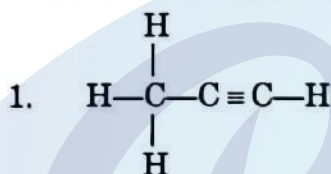

(ii) What is the special feature of the structure of ethyne ?

(iii) Name the saturated hydrocarbon containing two carbon atoms.

(iv) Give the structural formula of Acetic acid.

Q. 4. (b) Write a balanced chemical equation for the preparation of : [3]

- (i) Ethene from bromoethane
(ii) Ethyne using calcium carbide
(iii) Methane from sodium acetate.

(c) Name the following organic compounds : [4]

- (i) The compound with 3 carbon atoms whose functional group is a carboxyl.
(ii) The first homologue whose general formula is C_nH_{2n} .
(iii) The compound that reacts with acetic acid to form ethyl ethanoate.
(iv) The compound formed by complete chlorination of ethyne.

2018

Q. 1. (a) Choose the correct answer from the options given below : [2]

(ii) The organic compound which undergoes substitution reaction is :

- (A) C_2H_2 (B) C_2H_4
(C) $C_{10}H_{18}$ (D) C_2H_6

(iv) The IUPAC name of dimethyl ether is :

- (A) Ethoxy methane (B) Methoxy methane
(C) Methoxy ethane (D) Ethoxy ethane

(d) (i) Give the IUPAC name for each of the following : [5]

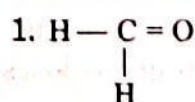

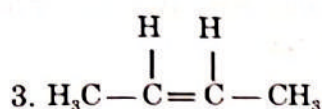
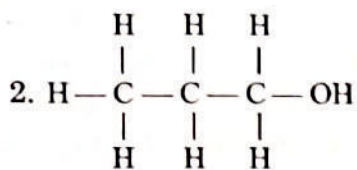

(ii) Write the structural formula of the two isomers of butane.

(g) Name the gas that is produced in each of the following cases : [1]

(v) Reaction of ethanol and sodium.

Q. 5. (a) Complete the following table which relates to the homologous series of hydrocarbons. [6]

General formula	IUPAC name of the homologous series	Characteristic bond type	IUPAC name of the first member of the series
$\text{C}_n\text{H}_{2n-2}$	(A)	(B)	(C)
$\text{C}_n\text{H}_{2n+2}$	(D)	(E)	(F)

Q. 6. (a) A compound X (having vinegar like smell) when treated with ethanol in the presence of the acid Z, gives a compound Y which has a fruity smell. [4]

The reaction is :



(i) Identify Y and Z.

(ii) Write the structural formula of X.

(iii) Name the above reaction.

2017

Q. 1. (a) Fill in the blank from the choices given in bracket : [1]

(v) The compound formed when ethene reacts with Hydrogen is
(CH_4 , C_2H_6 , C_3H_8)

(b) Choose the correct answer from the options given below : [1]

(ii) If the molecular formula of an organic compound is $\text{C}_{10}\text{H}_{18}$ it is :

1. Alkene
2. Alkane
3. Alkyne
4. Not a hydrocarbon

(c) Identify the substance underlined, the following case : [1]

(iv) An organic compound containing -- COOH functional group.

(d) Write a balanced chemical equation for the following : [1]

(iii) Preparation of methane from iodomethane.

(e) State one relevant observation for the following reaction : [1]

(i) Addition of ethyl alcohol to acetic acid in the presence of concentrated sulphuric acid.

(f) (i) Draw the structural formula for each of the following : [2½]

1. 2, 3 - dimethyl butane
2. diethyl ether
3. propanoic acid

Q. 6. (b) Identify the term or substance based on the descriptions given below : [4]

(i) Ice like crystals formed on cooling and organic acid sufficiently.

(ii) Hydrocarbon containing a triple bond used for welding purposes.

(iii) The property by virtue of which the compound has the same molecular formula but different structural formulae.

(iv) The compound formed where two alkyl group are linked by $\begin{array}{c} \text{O} \\ \parallel \\ -\text{C}- \end{array}$ group.

(c) Give a balanced chemical equation for each of the following : [2]

(i) Preparation of ethane from Sodium propionate.

(ii) Action of alcoholic KOH on bromoethane.

2016

Q. 1. (a) Fill in the blank with the choices given in brackets. [1]

(v) Conversion of ethene to ethane is an example of (hydration/hydrogenation)

(c) Write balanced chemical equation for the following : [1]

(v) Preparation of ethanol from Ethyl Chloride. .

(e) Identify the term/substance in each of the following : [2]

(iii) The catalyst used in the conversion of ethyne to ethane.

(iv) The type of reactions alkenes undergo.

(h) (i) Write the IUPAC names of each of the following : [3]

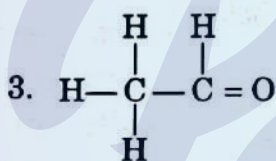
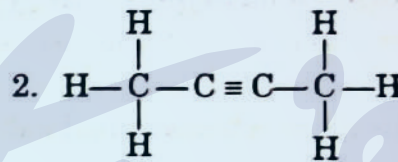
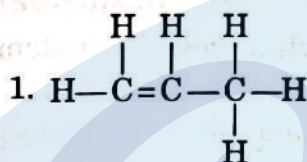

Q. 3. (a) Write a balanced chemical equation for each the following : [3]

(i) Burning of ethane in plentiful supply of air.

(ii) Action of water on Calcium carbide.

(iii) Heating of Ethanol at 170°C in the presence of conc. Sulphuric acid.

(b) Give the structural formulae of each of the following : [3]

(i) 2-methyl propane

(ii) Ethanoic acid

(iii) Butan-2-ol

(c) Equation for the reaction when compound A is bubbled through bromine dissolved in carbon tetrachloride is as follows : [2]

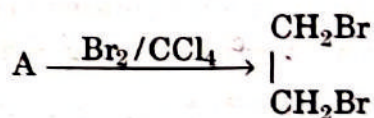

(i) Draw the structure of A.

(ii) State your observation during this reaction.

2015

Q. 1. (b) Choose the most appropriate answer for the following :

(ii) Identify the statement which does not describe the property of alkenes : [1]

(A) They are unsaturated hydrocarbons

- (B) They decolourise bromine water
- (C) They can undergo addition as well as substitution reactions
- (D) They undergo combustion with oxygen forming carbon dioxide and water.

- Q. 1. (d)** State one relevant observation for the following :
- (ii) When the gaseous product obtained by dehydration of ethyl alcohol is passed through bromine water. [1]
- Q. 3. (a)** Given balanced chemical equations for the following conversions :
- (i) Ethanoic acid to ethyl ethanoate.
 - (ii) Calcium carbide to ethyne.
 - (iii) Sodium ethanoate to methane. [3]
- (b) Using their structural formulae identify the functional group by circling them :
- (i) Dimethyl ether.
 - (ii) Propanone [2]
- (c) Name the following :
- (i) Process by which ethane is obtained from ethene.
 - (ii) A hydrocarbon which contributes towards the greenhouse effect.
 - (iii) Distinctive reaction that takes place when ethanol is treated with acetic acid.
 - (iv) The property of elements by virtue of which atoms of the element can link to each other in the form of a long chain or ring structure.
 - (v) Reaction when an alkyl halide is treated with alcoholic potassium hydroxide. [5]

2014

- Q. 1. (a)** Choose the correct answer from the options given below :
- (x) The I.U.P.A.C. name of acetylene is :
 - (A) propane
 - (B) propyne
 - (C) ethene
 - (D) ethyne [1]
- (b) Fill in the blank from the choices given within bracket :
- (ii) The compound formed when ethanol reacts with sodium is (sodium ethanoate, sodium ethoxide, sodium propanoate). [1]
- (c) Give one word or phrase for the following :
- (iv) Hydrocarbons containing a $\begin{array}{c} \text{O} \\ || \\ -\text{C}- \end{array}$ functional group. [1]
- (e) Write balanced equation for the following :
- (v) Preparation of ethane from sodium propionate. [1]
- (f) Distinguish between the following pair of compound using the test given within bracket :
- (v) Ethane and ethene (using alkaline potassium permanganate solution). [1]
- Q. 3. (a)** State the conditions required for the following reactions to take place :
- (i) Catalytic hydrogenation of ethyne. [1]
 - (ii) Preparation of ethyne from ethylene dibromide. [1]
- (c) Give balanced equation for the following :
- (ii) Preparation of ethanol from monochloroethane and aq. sodium hydroxide. [1]
- Q. 4. (a)** Give the structural formula of the following :
- (i) ethanol
 - (ii) 1-propanal
 - (iii) ethanoic acid
 - (iv) 1, 2, dichlorethane. [4]

2013

- Q. 1. (b) Identify the gas evolved in the following reaction when :
- (i) sodium propionate is heated with soda lime. [1]
 - (d) Give suitable chemical term for the following :
 - (iii) A reaction in which hydrogen of an alkene is replaced by a halogen. [1]
 - (e) Give a chemical test to distinguish between the following pair of compound :
 - (iii) Ethene gas and ethane gas [1]
 - (f) Choose the most appropriate answer from the following option :
 - (iii) Identify the statement that is incorrect about alkanes :
 - (A) They are hydrocarbons.
 - (B) There is a single covalent bond between carbon and hydrogen.
 - (C) They can undergo both substitution as well as addition reactions.
 - (D) On complete combustion they produce carbon dioxide and water. [1]
- Q. 6. (a) Give balanced equations for the laboratory preparations of the following organic compounds :
- (i) A saturated hydrocarbon from iodomethane.
 - (ii) An unsaturated hydrocarbon from an alcohol.
 - (iii) An unsaturated hydrocarbon from calcium carbide.
 - (iv) An alcohol from ethyl bromide. [4]
- (b) Give the structural formulae for the following :
- (i) An isomer of *n*-butane.
 - (ii) 2-propanol.
 - (iii) Diethyl ether. [3]
- (c) Give reasons for the following :
- (i) Methane does not undergo addition reactions, but ethene does.
 - (ii) Ethyne is more reactive than ethane.
 - (iii) Hydrocarbons are excellent fuels. [3]
- Q. 7. (b) Identify the following substance which are underlined :
- (ii) An acid which is present in vinegar. [1]

Practical Chemistry

2023

Q. 1. Choose the correct answer to the question from the given options. (Do not copy the questions, write the correct answer only).

(vi) The metallic hydroxide which forms a deep inky blue solution with excess ammonium hydroxide solution is : [1]

(a) $\text{Fe}(\text{OH})_2$

(b) $\text{Cu}(\text{OH})_2$

(c) $\text{Ca}(\text{OH})_2$

(d) $\text{Fe}(\text{OH})_3$

2020

Q. 1. (b) State one relevant observation for each of the following reactions : [1]

(iv) Zinc carbonate is heated strongly.

Q. 3. (c) Match the gases given in column I to the identification of the gases mentioned in column II : [4]

Column I	Column II
(i) Hydrogen sulphide	A. Turns acidified potassium dichromate solution green.
(ii) Nitric oxide	B. Turns lime water milky.
(iii) Carbon dioxide	C. Turns reddish brown when it reacts with oxygen.
(iv) Sulphur dioxide	D. Turns moist lead acetate paper silvery black.

Q. 5. (a) Distinguish between the following pairs of compounds using a reagent as a chemical test : [1]

(iii) Magnesium chloride and Magnesium nitrate solution.

Q. 6. (a) Identify the salts P, Q, R from the following observations : [3]

(i) Salt P has light bluish green colour. On heating, it produces a black coloured residue. Salt P produces brisk effervescence with dil. HCl and the gas evolved turns lime water milky, but no action with acidified potassium dichromate solution.

(ii) Salt Q is white in colour. On strong heating, it produces buff yellow residue and liberates reddish brown gas. Solution of salt Q produces chalky white insoluble precipitate with excess of ammonium hydroxide.

(iii) Salt R is black in colour. On reacting with concentrated HCl, it liberates a pungent greenish yellow gas which turns moist starch iodide paper blue black.

2019

Q. 3. (b) Distinguish between the following pairs of compounds using the reagent given in the bracket. [2]

(i) Manganese dioxide and copper (II) oxide. (using concentrated HCl)

(iii) Dilute hydrochloric acid and dilute sulphuric acid. (using lead nitrate solution)

2018

- Q. 1. (c)** Write a balanced chemical equation for the following : [3]
(v) Action of dilute hydrochloric acid on magnesium sulphite.
(g) Name the gas that is produced in the following case : [1]
(ii) Action of dilute hydrochloric acid on sodium sulphide.

2016

- Q. 4. (a)** Identify the gas evolved and give the chemical test in each of the following case : [2]
(i) Dilute hydrochloric acid reacts with sodium sulphite.
(ii) Dilute hydrochloric acid reacts with iron (II) sulphide.

2015

- Q. 1. (d)** State one relevant observation for each of the following :
(i) When crystals of copper nitrate are heated in a test tube. [1]
(iii) When hydrogen sulphide gas is passed through lead acetate solution. [1]
- Q. 4.** Identify the anion present in each of the following compounds :
(i) A salt M on treatment with concentrated sulphuric acid produces a gas which fumes in moist air gives dense fumes with ammonia.
(ii) A salt D on treatment with dilute sulphuric acid produces a gas which turns lime water milky but has no effect on acidified potassium dichromate solution.

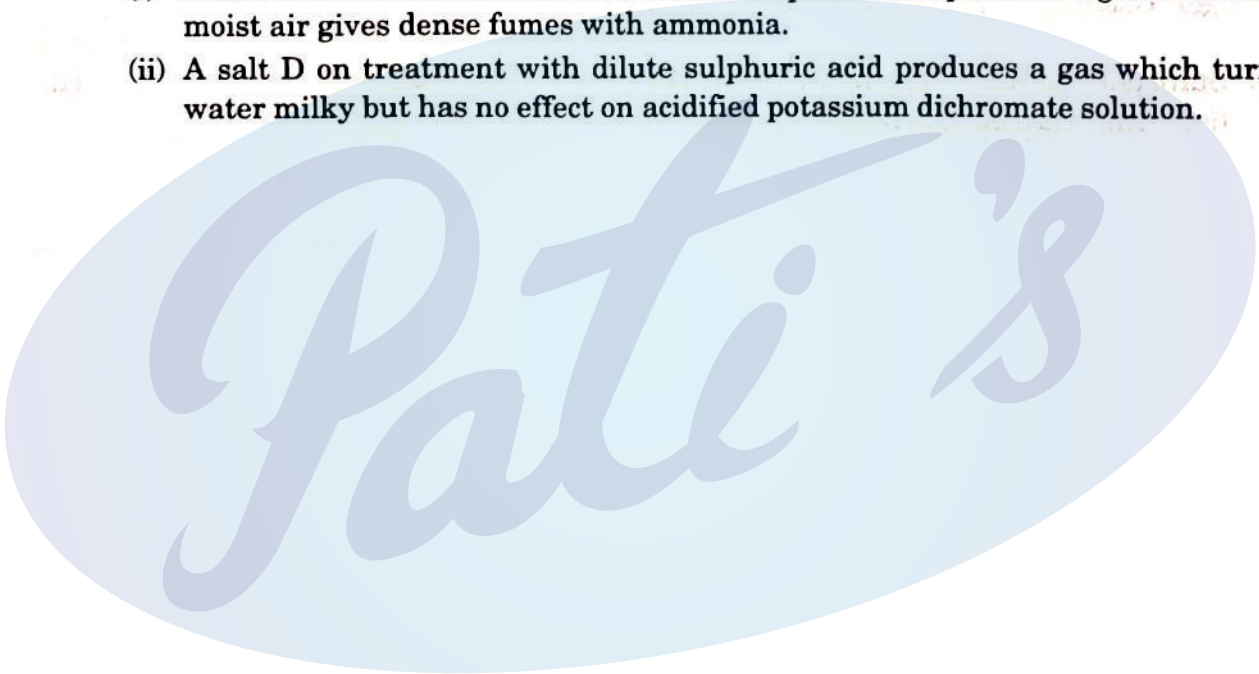



Prepare for ICSE CLASS 10
Free Resources

SCAN QR CODE Now



History/Civics

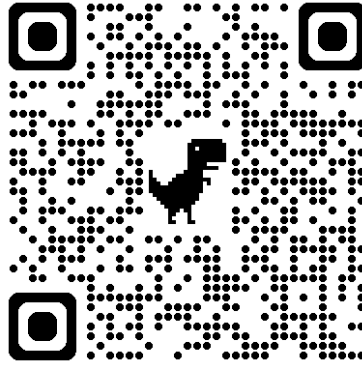

Geography



Maths



Physics

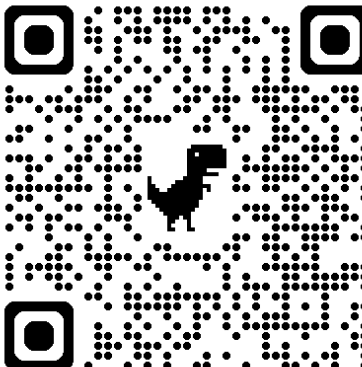

Chemistry

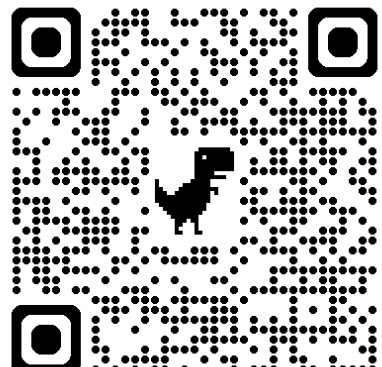

Biology



Hindi



Physical
Education



Computer
Applications





Prepare for ICSE CLASS 10
Free Resources

SCAN QR CODE Now

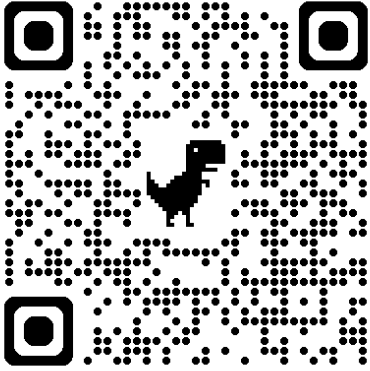

Economics



Commercial
Studies

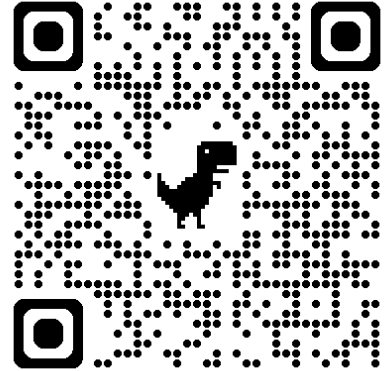

French

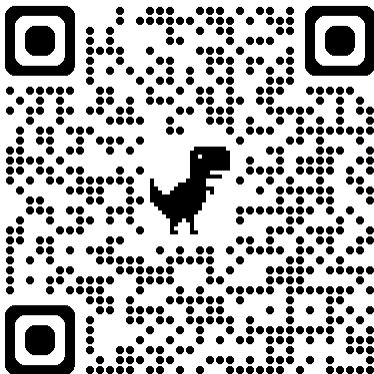

Robotics & AI

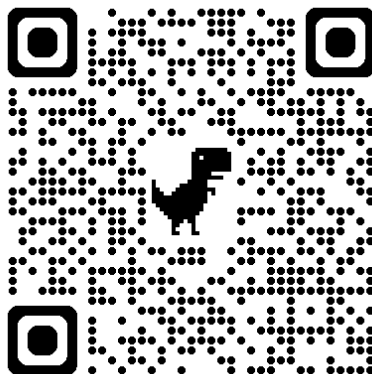

Home Science



EVS

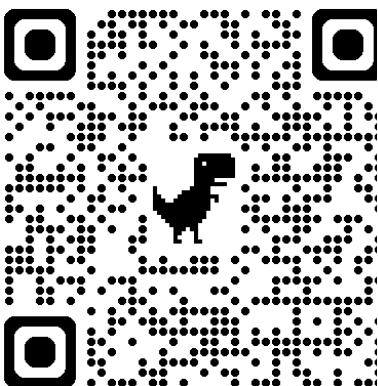

Marathi

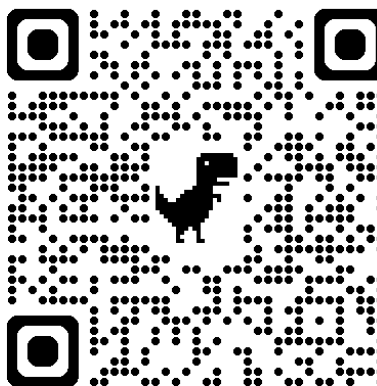

Gujarati

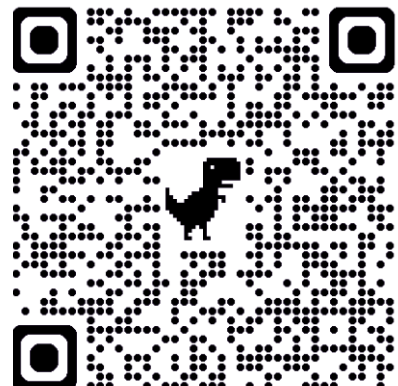

Odiya



Scan QR code for Free Access to 500+ Prelim Papers across 20 subjects

